

General Purpose Cortex-M0+ Microcontroller Flash 64KB, SRAM 6KB, ADC, LCD Driver

Datasheet Version 1.40

Features

- High performance Cortex-M0+ core
- 64KB/32KB code flash memory
- 6KB SRAM
- LED Display Drive Capability
 - Max. 120mA of sink current capability for output of 8 pins(PD0 to PD7)
- Watchdog Timer
- Ten general purpose timers
 - Periodic, one-shot, PWM, capture
- 12-bit ADC, 50ksp/s
 - 14-channel inputs
- External communication ports
 - 4xUSART(UART + SPI)
 - 3xI2C
 - 2xUART
- Clock monitoring function for system clock
- LCD driver for up to 8x39 segments
 - Duty selectable, resistor bias
 - 16-step contrast control
- 16-bit CRC generator
 - CRC-CCITT, CRC-16
- SWD debug interface
- Supports USART (UART + SPI) ISP
- Seven types of package options
 - LQFP80-1212, LQFP80-1414
 - LQFP64-1010, LQFP64-1212
 - LQFP64-1414, LQFP48-0707
 - MQFP44-1010
- Commercial grade (-40°C to +85°C)
- Industrial grade (-40°C to +105°C)

Applications

- Smart door lock
- Air cleaner
- General purpose

Product Selection Table

Table 1. Device Summary

Part Number	Flash	SRAM	USART	UART	I2C	TIMER	ADC	I/O	Package
A31G123ML	64KB	6KB	4	2	3	10	14 ch	77	80LQFP-1212
A31G123MM*	64KB	6KB	4	2	3	10	14 ch	77	80LQFP-1414
A31G123RL*	64KB	6KB	3	2	3	10	14 ch	61	64LQFP-1010
A31G123RM*	64KB	6KB	3	2	3	10	14 ch	61	64LQFP-1212
A31G123RN*	64KB	6KB	3	2	3	10	14 ch	61	64LQFP-1414
A31G123CL*	64KB	6KB	2	2	2	10	11 ch	45	48LQFP-0707
A31G123SQ*	64KB	6KB	2	2	2	10	9 ch	41	44MQFP-1010
A31G122ML*	32KB	6KB	4	2	3	10	14 ch	77	80LQFP-1212
A31G122MM*	32KB	6KB	4	2	3	10	14 ch	77	80LQFP-1414
A31G122RL*	32KB	6KB	3	2	3	10	14 ch	61	64LQFP-1010
A31G122RM*	32KB	6KB	3	2	3	10	14 ch	61	64LQFP-1212

* For available options or further information on the devices with “*” marks, please contact [the ABOV Sales Office](#).

Contents

1	Description	8
1.1	Device overview	9
1.2	Block diagram	10
1.3	Functional description	11
1.3.1	ARM Cortex-M0+	11
1.3.2	Nested vector-interrupt controller (NVIC)	11
1.3.3	64KB/32KB internal code flash memory	11
1.3.4	6KB internal SRAM	11
1.3.5	Boot logic	11
1.3.6	System Control Unit (SCU)	11
1.3.7	24-bit Watchdog timer (WDT)	11
1.3.8	Multi-purpose 16-bit timer and 32-bit timer	11
1.3.9	16-bit Timer with 6 Channel PWMs	12
1.3.10	USART (UART and SPI)	12
1.3.11	Inter-Integrated Circuit interface (I2C)	12
1.3.12	Universal Asynchronous Receiver/Transmitter (UART)	12
1.3.13	General PORT I/Os (GPIO)	12
1.3.14	12-bit Analog-to-Digital Converter (ADC)	12
1.3.15	LCD driver/controller	12
1.3.16	16-bit Cyclic Redundancy Check (CRC) generator	12
2	Pinouts and pin descriptions	13
2.1	Pinouts	13
2.2	Pin description	17
3	System and memory overview	24
3.1	Cortex®-M0+ core	24
3.2	Interrupt controller	25
3.3	Boot mode	28
3.3.1	Boot mode pins	28
3.3.2	Boot mode connection	29
3.4	Memory organization	30
3.4.1	Memory map	30
3.4.2	Internal SRAM	31
3.4.3	Flash memory	31
3.4.4	Configure option area	33
3.4.5	Configuration option page	33
4	SCU (System Control Unit)	35
4.1	SCU block diagram	35
4.2	Clock system	36
4.2.1	HCLK clock domain	37
4.2.2	Miscellaneous clock domain	37
4.2.3	PCLK clock domain	37
4.2.4	Clock configuration procedure	38
4.3	Reset	40
4.3.1	Cold reset	40
4.3.2	Warm reset	41
4.3.3	LVR reset	42
4.4	Operation mode	44
4.4.1	Run mode	44
4.4.2	Sleep mode	44

4.4.3	Deep sleep mode	44
4.5	Pin description for SCU.....	46
5	PCU and GPIO.....	47
5.1	PCU and GPIO block diagrams	47
5.2	I/O port block diagram.....	48
5.3	Pin multiplexing	49
6	WDT	52
6.1	WDT block diagram.....	52
7	WT.....	53
7.1	WT block diagram	53
8	Timer counters	54
8.1	Timer counter 10/11/12/13/14/15/16	54
8.1.1	Timer counter 10/11/12/13/14/15/16 block diagram	55
8.1.2	Pin description for timer counter 10/11/12/13/14/15/16	55
8.2	Timer counter 20	56
8.2.1	Timer counter 20 block diagram.....	56
8.2.2	Pin description for Timer counter 20	57
8.3	Timer counter 21	58
8.3.1	Timer counter 21 block diagram.....	58
8.3.2	Pin description for Timer counter 21	59
8.4	Timer counter 30	60
8.4.1	Timer counter 30 block diagram.....	61
8.4.2	Pin description for Timer counter 30	62
9	12-bit A/D Converter.....	63
9.1	12-bit ADC block diagram	64
9.2	Pin description for 12-bit ADC.....	65
10	USART 10/11/12/13 and UART 0/1.....	66
10.1	USART 10/11/12/13	66
10.1.1	USART 10/11/12/13 block diagram	67
10.1.2	Pin description for USART 10/11/12/13.....	68
10.2	UART 0/1.....	69
10.2.1	UART 0/1 block diagram	70
10.2.2	Pin description for UART 0/1	70
11	I2C 0/1/2 interface.....	71
11.1	I2C 0/1/2 block diagram	72
11.2	Pin description for I2C 0/1/2.....	72
12	LCD driver	73
12.1	LCD driver block diagram	73
12.2	Pin description for LCD driver	74
13	CRC and checksum	75
13.1	CRC and checksum block diagram.....	76
14	Electrical characteristics.....	77
14.1	Absolute maximum ratings.....	77
14.2	Recommended operating conditions	78
14.3	ADC characteristics.....	79
14.4	Power-on reset characteristics.....	80
14.5	Low voltage reset characteristics	81
14.6	Low voltage indicator characteristics	82
14.7	High frequency internal RC oscillator characteristics	83
14.8	Internal watchdog timer RC oscillator characteristics	84

14.9	LCD voltage characteristics	85
14.10	DC electrical characteristics.....	86
14.11	Supply current characteristics.....	87
14.12	AC characteristics	88
14.13	SPI characteristics	89
14.14	I2C characteristics.....	90
14.15	UART timing characteristics.....	91
14.16	Data retention voltage in Stop mode.....	92
14.17	Internal flash characteristics	93
14.18	Input/output capacitance	94
14.19	Main oscillator characteristics	95
14.20	Sub-oscillator characteristics	96
14.21	Main oscillation stabilization time	97
14.22	Sub-oscillation stabilization time	98
14.23	Operating voltage range	99
14.24	Recommended circuit and layout.....	100
15	Package information	102
15.1	80 LQFP 12x12 package information	102
15.2	80 LQFP 14x14 package information	103
15.3	64 LQFP 10x10 package information	104
15.4	64 LQFP 12x12 package information	105
15.5	64 LQFP 14x14 package information	106
15.6	48 LQFP package information	107
15.7	44 MQFP package information	108
16	Ordering information	109
17	Development tools	110
17.1	Compiler.....	110
17.2	Debugger	111
17.3	Programmer	112
17.4	SWD debug mode and E-PGM+ connection	113
	Revision history.....	114

List of figures

Figure 1. A31G12x series Block Diagram.....	10
Figure 2. LQFP-80 Pinouts	13
Figure 3. LQFP-64 Pinouts	14
Figure 4. LQFP-48 Pinouts	15
Figure 5. MQFP-44 Pinouts	16
Figure 6. Connection Diagram of UART Boot.....	29
Figure 7. Connection Diagram of SPI Boot.....	29
Figure 8. Main Memory Map	30
Figure 9. Internal Flash Memory Block Diagram.....	32
Figure 10. Configure Option Area Structure.....	33
Figure 11. SCU Block Diagram	35
Figure 12. Clock Source Configuration	36
Figure 13. Miscellaneous Clock Configuration.....	37
Figure 14. Clock Configuration Procedure	39
Figure 15. Power-up POR Sequence	40
Figure 16. Reset Configuration	42
Figure 17. LVR Reset Timing Diagram.....	43
Figure 18. Operating Mode	44
Figure 19. PCU Block Diagram	47
Figure 20. GPIO Block Diagram	47
Figure 21. I/O Port Block Diagram (External Interrupt I/O pins)	48
Figure 22. I/O Port Block Diagram (General I/O pins)	48
Figure 23. WDT Block Diagram	52
Figure 24. WT Block Diagram	53
Figure 25. Timer Counter n Block Diagram (n = 10, 11, 12, 13, 14, 15 and 16).....	55
Figure 26. Timer Counter 20 Block Diagram.....	56
Figure 27. Timer Counter 21 Block Diagram.....	58
Figure 28. Timer Counter 30 Block Diagram.....	61
Figure 29. 12-bit ADC Block Diagram	64
Figure 30. UART n Block Diagram of USART (n = 10, 11, 12 and 13)	67
Figure 31. SPIn Block Diagram of USART (n = 10, 11, 12 and 13)	68
Figure 32. UART 0/1 Block Diagram	70
Figure 33. I2C Block Diagram (n = 0, 1 and 2)	72
Figure 34. LCD Driver Block Diagram.....	73
Figure 35. CRC and Checksum Block Diagram.....	76
Figure 36. AC Timing.....	88
Figure 37. SPI Timing.....	89
Figure 38. I2C Timing.....	90
Figure 39. UART Timing Characteristics.....	91
Figure 40. Timing Waveform of UART Module	91
Figure 41. Crystal/Ceramic Oscillator	95
Figure 42. External Clock.....	95
Figure 43. Crystal Oscillator.....	96
Figure 44. External Clock.....	96
Figure 45. Clock Timing Measurement at XIN	97
Figure 46. Clock Timing Measurement at SXIN.....	98
Figure 47. Operating Voltage Range	99
Figure 48. Recommended Circuit and Layout	100
Figure 49. Recommended Circuit and Layout with SMPS Power	101

Figure 50. 80 LQFP 12 x 12 Package Outline	102
Figure 51. 80 LQFP 14 x 14 Package Outline	103
Figure 52. 64 LQFP 10 x 10 Package Outline	104
Figure 53. 64 LQFP 12 x 12 Package Outline	105
Figure 54. 64 LQFP 14 x 14 Package Outline	106
Figure 55. 48 LQFP 07 x 07 Package Outline	107
Figure 56. 44 MQFP 10 x 10 Package Outline	108
Figure 57. A31G12x series Numbering Nomenclature	109
Figure 58. A-Link and Pin Descriptions	111
Figure 59. E-PGM+ (Single Writer) and Pin Descriptions	112
Figure 60. E-Gang4 and E-Gang6 (for Mass Production)	112
Figure 61. Connection between A31G12x series and E-PGM+ using SWD Debugger Interface	113

List of tables

Table 1. Device Summary	1
Table 2. A31G12x series features and peripheral counts	9
Table 3. Pin Description	17
Table 4. Interrupt Vector Map	25
Table 5. Boot Mode Pin List	28
Table 6. Internal Flash Memory Specification	31
Table 7. Configuration Option Area Map	34
Table 8. Clock Sources	37
Table 9. Functional table on current mode	45
Table 10. Pins and External Signals for SCU	46
Table 11. GPIO Alternative Functions	49
Table 12. Pins and External Signals for Timer Counter n (n = 10, 11, 12, 13, 14, 15 and 16)	55
Table 13. Pins and External Signals for Timer Counter 20	57
Table 14. Pins and External Signals for Timer Counter 21	59
Table 15. Pins and External Signals for Timer Counter 30	62
Table 16. Pins and External Signals for 12-bit ADC	65
Table 17. Pins and External Signals for USART 10/11/12/13	68
Table 18. Pins and External Signals for UART 0/1	70
Table 19. Pins and External Signals for I2C (n = 0, 1 and 2)	72
Table 20. Pins and External Signals for LCD Driver	74
Table 21. Absolute Maximum Ratings	77
Table 22. Recommended Operating Conditions	78
Table 23. ADC Characteristics	79
Table 24. Power-on Reset Characteristics	80
Table 25. Low Voltage Reset Characteristics	81
Table 26. Low Voltage Indicator Characteristics	82
Table 27. High Frequency Internal RC Oscillator Characteristics	83
Table 28. Internal Watchdog Timer RC Oscillator Characteristics	84
Table 29. LCD Voltage Characteristics	85
Table 30. DC Electrical Characteristics	86
Table 31. Supply Current Characteristics	87
Table 32. AC Characteristics	88
Table 33. SPI Characteristics	89
Table 34. I2C Characteristics	90
Table 35. UART Timing Characteristics (PCLK=11.1MHz)	91
Table 36. Data Retention Voltage in Stop Mode	92
Table 37. Internal Flash Characteristics	93
Table 38. Input/Output Capacitance	94
Table 39. Main Oscillator Characteristics	95
Table 40. Sub-oscillator Characteristics	96
Table 41. Main Oscillation Stabilization Time	97
Table 42. Sub-oscillation Stabilization Time	98
Table 43. A31G12x series Ordering Information	109

1 Description

The A31G12x series is a microcontroller based on ARM Cortex-M0+ core with a flash memory of up to 64KB, and an SRAM of 6KB. Operation voltage of the device is 1.8V to 5.5V. It provides a highly flexible and cost effective solution for many embedded control applications.

The A31G12x series has 16-bit timers, 32-bit timers, a 16-bit timer with 6-channel PWM, 12-bit ADC, CRC generator, UART, USART, I2C, LCD driver/controller, etc. The A31G12x series also has a POR, LVR, LVI, and an internal RC oscillator. The A31G12x series support sleep and deep sleep modes to reduce power consumption.

1.1 Device overview

Table 2. A31G12x series features and peripheral counts

Peripheral	Device	A31G12x
CPU		Cortex-M0+
Flash ROM (Kbytes)		64
SRAM (bytes)		6KB
LED Display Drive Capability		Max. 120mA of sink current capability for output of 8 pins (PD0 to PD7)
I/O		77 programmable
Timers		Watchdog timer
		Ten general purpose timers — Periodic, one-shot, PWM, capture mode
LCD driver		<ul style="list-style-type: none"> • 39 segments and 8 commons • Duty selectable, resistor bias • 16-step contrast control
ADC		14-channel input, 12-bit ADC with 50ksps
CRC generator		16-bit CRC generator, CRC-16, CRC-CCITT
External communication ports		<ul style="list-style-type: none"> • 4 USARTs (UART + SPI) • 3 I²C • 2 UART
System fail-safe function		Clock monitoring
Debug interface		SWD debug interface
Packages		<ul style="list-style-type: none"> • LQFP 80-1212 (0.5mm pitch) • LQFP 80-1414 (0.65mm pitch) • LQFP 64-1010 (0.5mm pitch) • LQFP 64-1212 (0.65mm pitch) • LQFP 64-1414 (0.8mm pitch) • LQFP 48-0707 (0.5mm pitch) • MQFP 44-1010 (0.8mm pitch)
Operating temperature		<ul style="list-style-type: none"> • -40°C to +85°C (commercial grade) • -40°C to +105°C (Industrial grade)

1.2 Block diagram

Figure 1 shows a block diagram of A31G12x series.

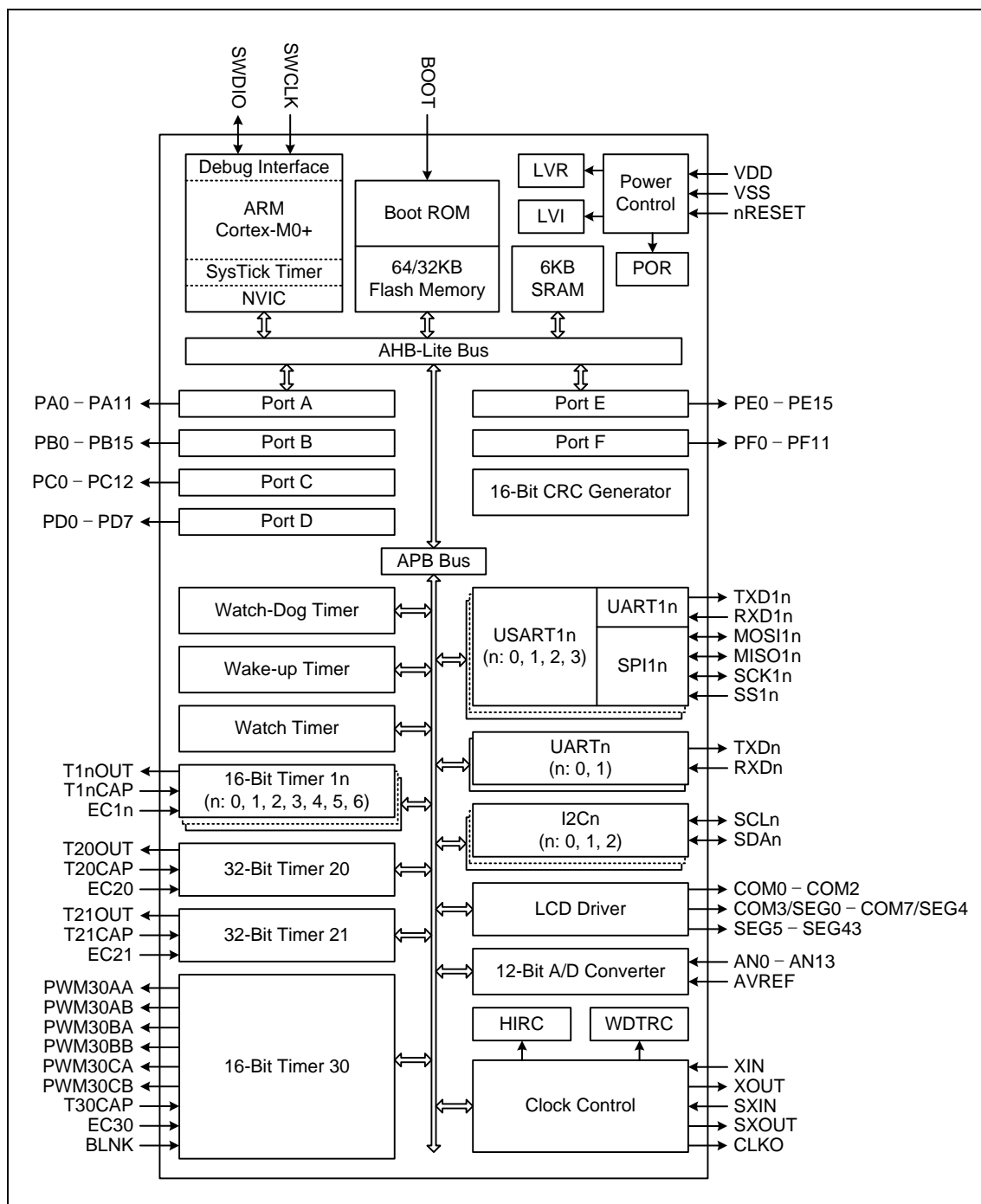

Figure 1. A31G12x series Block Diagram

1.3 Functional description

Main features of A31G12x series are summarized below:

1.3.1 ARM Cortex-M0+

Cortex-M0+ processor has very low gate count characteristic and high energy efficiency. It is developed for microcontrollers and deeply embedded applications that require an area-optimized and low-power processor.

The core system timer (SYSTICK) provides a simple 24-bit timer, which can be used for a real time operating system (RTOS). It can be used as a simple counter too.

The Cortex-M0+ processor implements the ARMv6-M Thumb instruction set, including a number of 32-bit instructions that use Thumb-2 technology. Hardware single-cycle multiplication is available. Integrated Nested Vectored Interrupt Controller (NVIC) provides deterministic interrupt handling, and SWD debugging features offer the MCU emulation.

1.3.2 Nested vector-interrupt controller (NVIC)

External interrupt signals connect to the NVIC, and the NVIC prioritizes the interrupts. Software can set the priority of each interrupt.

The NVIC embedded in the Cortex-M0+ processor core is capable of processing low latency interrupts and efficient processing of late arriving interrupts. All NVIC registers are accessible only using word transfers.

1.3.3 64KB/32KB internal code flash memory

A31G12x series has built-in code flash memory of 64KB or 32KB. It supports self-programming feature, and supports ISP and JTAG programming in boot or debug mode.

1.3.4 6KB internal SRAM

On-chip 6KB SRAM is used as a working memory space and as a program code area temporarily.

1.3.5 Boot logic

A boot logic supports flash programming. The boot logic will be activated when the external boot pin was set to boot mode.

1.3.6 System Control Unit (SCU)

An SCU block manages internal power, clock, reset and operation mode. It also controls the analog blocks (Oscillator Block, VDC and LVR).

1.3.7 24-bit Watchdog timer (WDT)

A Watchdog timer monitors the system. It generates internal reset or interrupt to notice abnormal status of the system.

1.3.8 Multi-purpose 16-bit timer and 32-bit timer

Seven-channel 16-bit and two-channel 32-bit general-purpose timers support the functions introduced below:

- Periodic timer mode
- Counter mode
- PWM mode
- Capture mode

1.3.9 16-bit Timer with 6 Channel PWMs

The 16-bit timer has 6 channels of PWMs for 3-phase motor application. 16-bit up/down counter with prescaler supports both triangular and sawtooth waveform.

The PWM has ability to generate internal ADC trigger signal to measure the signal on time.

Dead time insertion and emergency stop functionality make sure that the chip and the system are under a safe condition.

1.3.10 USART (UART and SPI)

USART supports UART and SPI mode. The A31G12x series has 4 channel USART modules.

Boot mode uses this USART block to download flash program.

1.3.11 Inter-Integrated Circuit interface (I2C)

A31G12x series has three channels of I2C block and supports up to 1MHz I2C communication. Master and slave modes are available.

1.3.12 Universal Asynchronous Receiver/Transmitter (UART)

A31G12x series has two channels of UART block. For accurate baud rate control, a fractional baud-rate generation feature is available.

1.3.13 General PORT I/Os (GPIO)

12-bit PA port, 16-bit PB port, 13-bit PC port, 8-bit PD port, 16-bit PE port, and 12-bit PF port are available and provide multiple functions.

- General I/O port
- External interrupt input port and on-chip input debounce filter
- Programmable pull-up, pull-down, and open-drain selection

1.3.14 12-bit Analog-to-Digital Converter (ADC)

An ADC can convert analog signal at a conversion rate of up to 50ksps. 14-channel analog MUX provides various combinations of data from external analog signals.

1.3.15 LCD driver/controller

A LCD driver supports an internal resistor bias, 16-step contrast control, automatic bias control, and various duties.

1.3.16 16-bit Cyclic Redundancy Check (CRC) generator

A31G12x series has two polynomials for the CRC generator: CRC-CCITT and CRC-16.

2 Pinouts and pin descriptions

In chapter 2, pinouts and pin descriptions of A31G12x series are introduced.

2.1 Pinouts

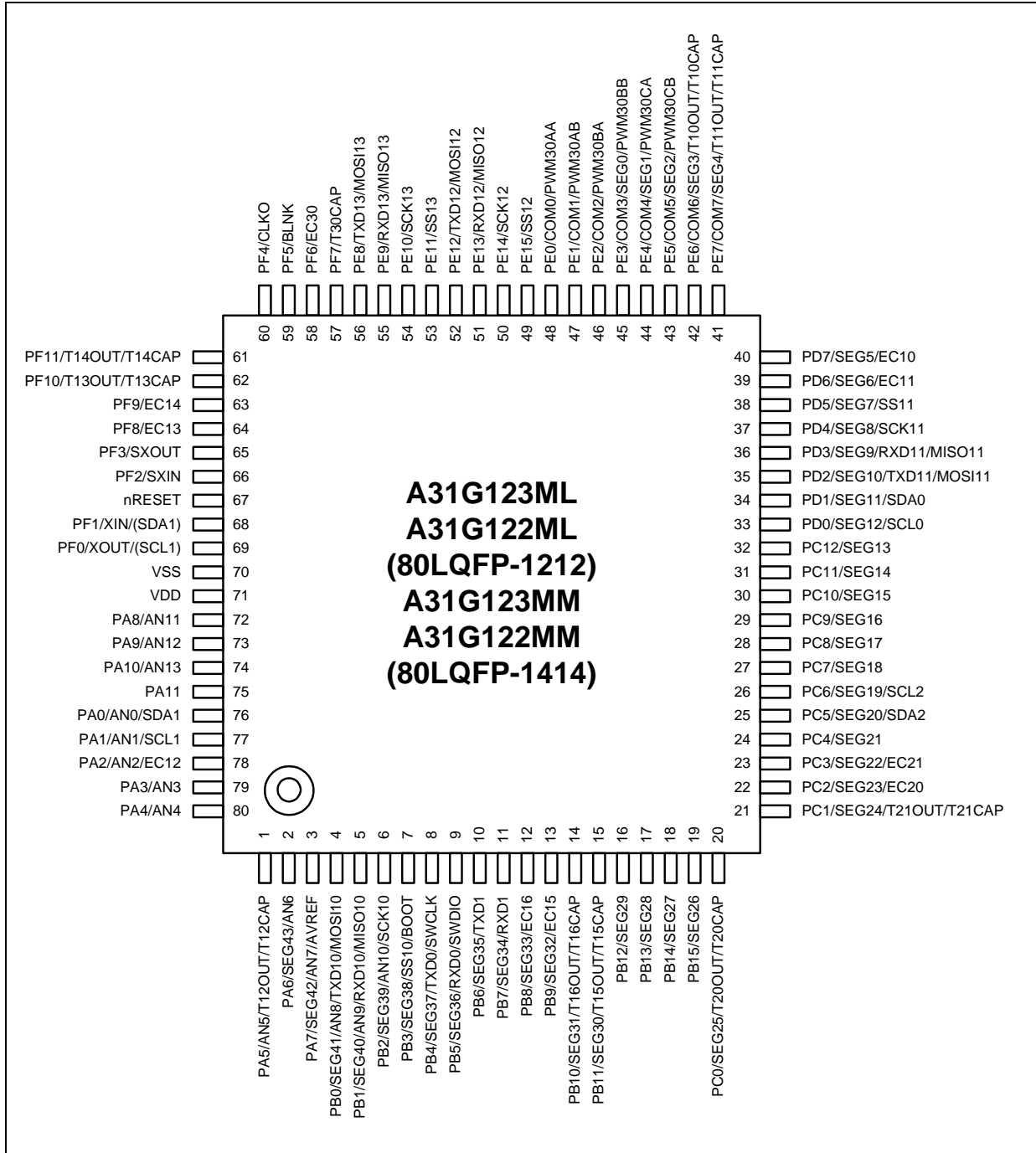

Figure 2. LQFP-80 Pinouts

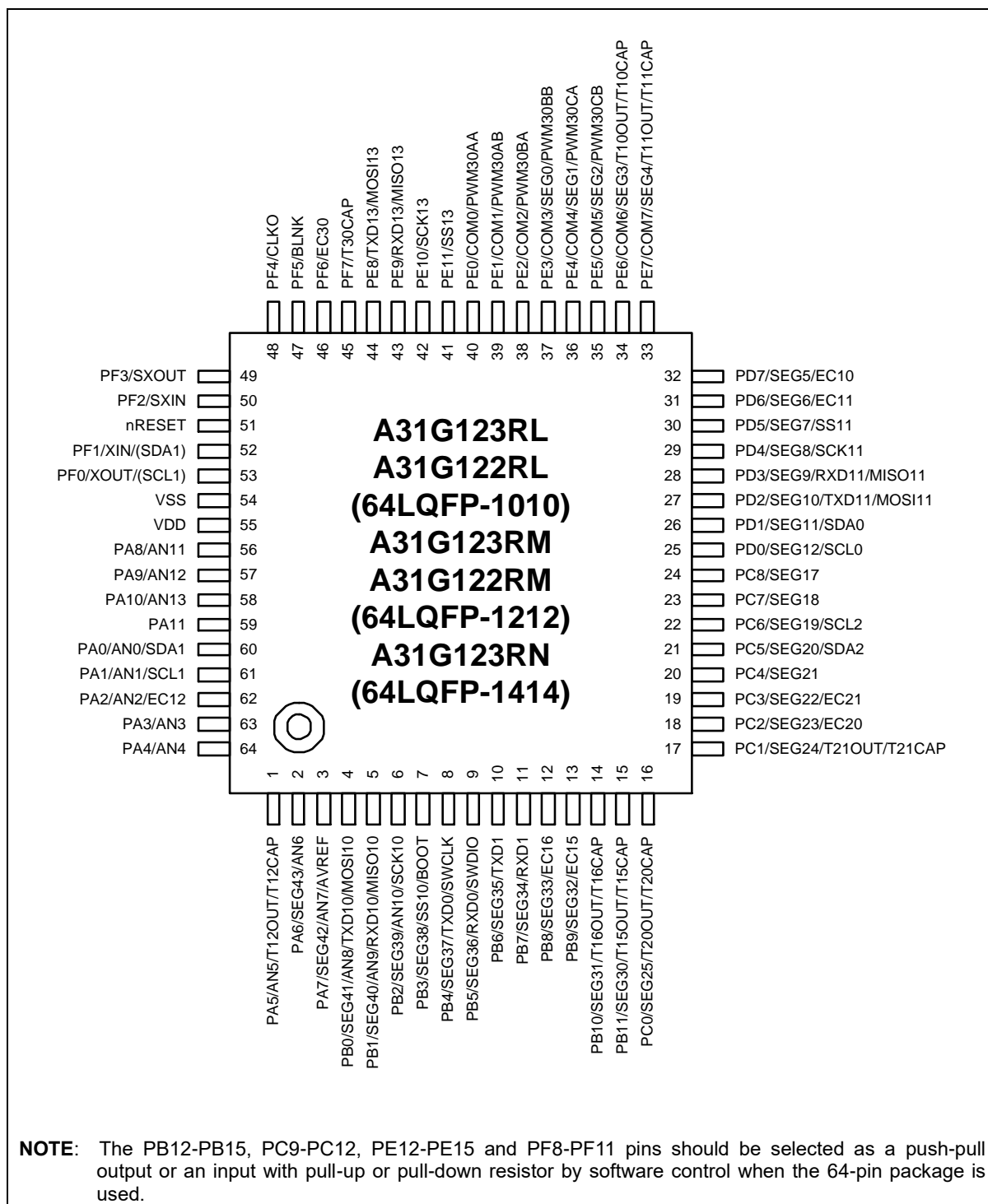

Figure 3. LQFP-64 Pinouts

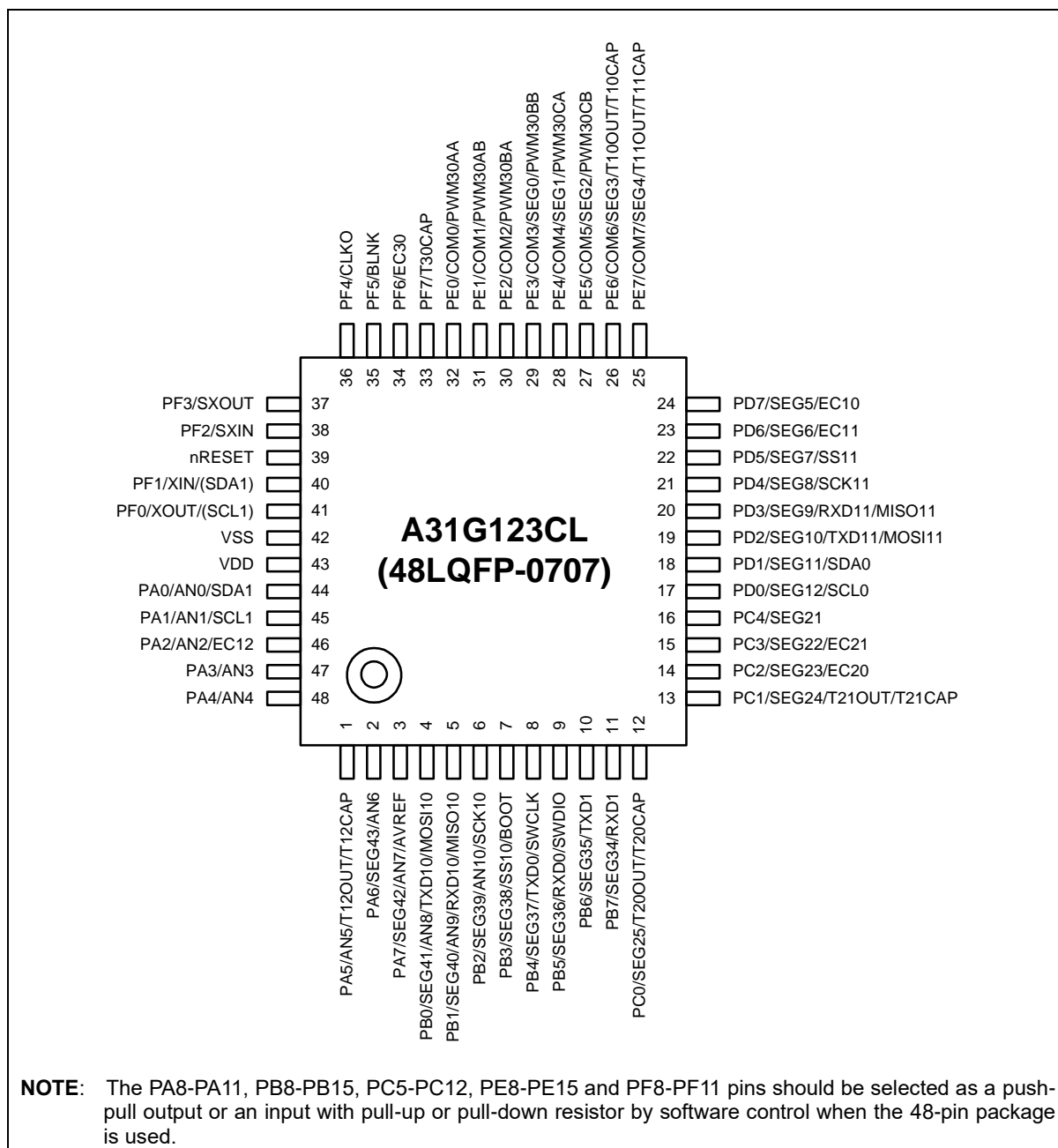

Figure 4. LQFP-48 Pinouts

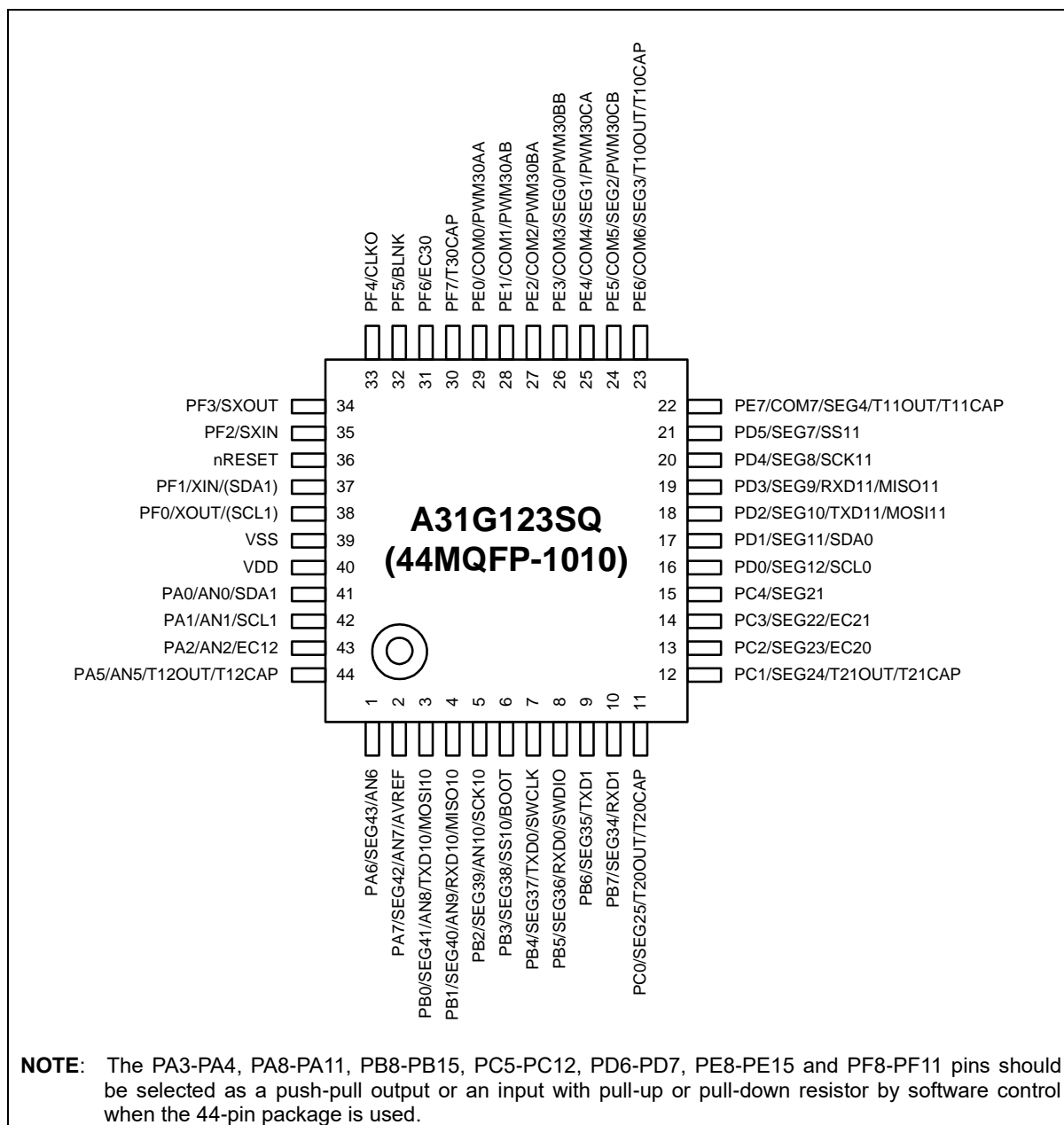

Figure 5. MQFP-44 Pinouts

2.2 Pin description

Table 3 shows pin configuration containing one pair of power/ground and other dedicated pins. Multi-function pins have up to five selections of functions including GPIO.

Table 3. Pin Description

Pin number				Pin name	Type	Description	Remark
LQFP-80	LQFP-64	LQFP-48	MQFP-44				
1	1	1	44	PA5*	IOUDS	PORT A Bit 5 Input/Output	
				AN5	IA	A/D Converter Analog Input 5	
				T12OUT	O	Timer 12 Pulse Output	
				T12CAP	I	Timer 12 Capture Input	
2	2	2	1	PA6*	IOUDS	PORT A Bit 6 Input/Output	
				SEG43	O	LCD Segment Signal Output	
				AN6	IA	A/D Converter Analog Input 6	
3	3	3	2	PA7*	IOUDS	PORT A Bit 7 Input/Output	
				SEG42	O	LCD Segment Signal Output	
				AN7	IA	A/D Converter Analog Input 7	
				AVREF	IA	A/D Converter Reference Input	
4	4	4	3	PB0*	IOUDS	PORT B Bit 0 Input/Output	
				SEG41	O	LCD Segment Signal Output	
				AN8	IA	A/D Converter Analog Input 8	
				TXD10	O	UART Data Output	
				MOSI10	I/O	SPI Master Output, Slave Input	
5	5	5	4	PB1*	IOUDS	PORT B Bit 1 Input/Output	
				SEG40	O	LCD Segment Signal Output	
				AN9	IA	A/D Converter Analog Input 9	
				RXD10	I	UART Data Input	
				MISO10	I/O	SPI Master Input, Slave Output	
6	6	6	5	PB2*	IOUDS	PORT B Bit 2 Input/Output	
				SEG39	O	LCD Segment Signal Output	
				AN10	IA	A/D Converter Analog Input 10	
				SCK10	I/O	SPI Clock Input/Output	
7	7	7	6	PB3	IOUDS	PORT B Bit 3 Input/Output	
				SEG38	O	LCD Segment Signal Output	
				SS10	I	SPI Slave Select Input	
				BOOT*	I	Boot Mode Selection Input	Pull-up
8	8	8	7	PB4	IOUDS	PORT B Bit 4 Input/Output	
				SEG37	O	LCD Segment Signal Output	
				TXD0	O	UART Data Output	
				SWCLK*	I	SWD Clock Input	Pull-down

Table 3. Pin Description (continued)

Pin number				Pin name	Type	Description	Remark
LQFP-80	LQFP-64	LQFP-48	MQFP-44				
9	9	9	8	PB5	IOUDS	PORT B Bit 5 Input/Output	
				SEG36	O	LCD Segment Signal Output	
				RXD0	I	UART Data Input	
				SWDIO*	I/O	SWD Data Input/Output	Pull-up
10	10	10	9	PB6*	IOUDS	PORT B Bit 6 Input/Output	
				SEG35	O	LCD Segment Signal Output	
				TXD1	O	UART Data Output	
11	11	11	10	PB7*	IOUDS	PORT B Bit 7 Input/Output	
				SEG34	O	LCD Segment Signal Output	
				RXD1	I	UART Data Input	
12	12	-	-	PB8*	IOUDS	PORT B Bit 8 Input/Output	
				SEG33	O	LCD Segment Signal Output	
				EC16	I	Timer 16 Event Count Input	
13	13	-	-	PB9*	IOUDS	PORT B Bit 9 Input/Output	
				SEG32	O	LCD Segment Signal Output	
				EC15	I	Timer 15 Event Count Input	
14	14	-	-	PB10*	IOUDS	PORT B Bit 10 Input/Output	
				SEG31	O	LCD Segment Signal Output	
				T16OUT	O	Timer 16 Pulse Output	
				T16CAP	I	Timer 16 Capture Input	
15	15	-	-	PB11*	IOUDS	PORT B Bit 11 Input/Output	
				SEG30	O	LCD Segment Signal Output	
				T15OUT	O	Timer 15 Pulse Output	
				T15CAP	I	Timer 15 Capture Input	
16	-	-	-	PB12*	IOUDS	PORT B Bit 12 Input/Output	
				SEG29	O	LCD Segment Signal Output	
17	-	-	-	PB13*	IOUDS	PORT B Bit 13 Input/Output	
				SEG28	O	LCD Segment Signal Output	
18	-	-	-	PB14*	IOUDS	PORT B Bit 14 Input/Output	
				SEG27	O	LCD Segment Signal Output	
19	-	-	-	PB15*	IOUDS	PORT B Bit 15 Input/Output	
				SEG26	O	LCD Segment Signal Output	
20	16	12	11	PC0*	IOUDS	PORT C Bit 0 Input/Output	
				SEG25	O	LCD Segment Signal Output	
				T20OUT	O	Timer 20 Pulse Output	
				T20CAP	I	Timer 20 Capture Input	

Table 3. Pin Description (continued)

Pin number				Pin name	Type	Description	Remark
LQFP-80	LQFP-64	LQFP-48	MQFP-44				
21	17	13	12	PC1*	IOUDS	PORT C Bit 1 Input/Output	
				SEG24	O	LCD Segment Signal Output	
				T21OUT	O	Timer 21 Pulse Output	
				T21CAP	I	Timer 21 Capture Input	
22	18	14	13	PC2*	IOUDS	PORT C Bit 2 Input/Output	
				SEG23	O	LCD Segment Signal Output	
				EC20	I	Timer 20 Event Count Input	
23	19	15	14	PC3*	IOUDS	PORT C Bit 3 Input/Output	
				SEG22	O	LCD Segment Signal Output	
				EC21	I	Timer 21 Event Count Input	
24	20	16	15	PC4*	IOUDS	PORT C Bit 4 Input/Output	
				SEG21	O	LCD Segment Signal Output	
25	21	-	-	PC5*	IOUDS	PORT C Bit 5 Input/Output	
				SEG20	O	LCD Segment Signal Output	
				SDA2	I/O	I2C Data Input/Output	
26	22	-	-	PC6*	IOUDS	PORT C Bit 6 Input/Output	
				SEG19	O	LCD Segment Signal Output	
				SCL2	I/O	I2C Clock Input/Output	
27	23	-	-	PC7*	IOUDS	PORT C Bit 7 Input/Output	
				SEG18	O	LCD Segment Signal Output	
28	24	-	-	PC8*	IOUDS	PORT C Bit 8 Input/Output	
				SEG17	O	LCD Segment Signal Output	
29	-	-	-	PC9*	IOUDS	PORT C Bit 9 Input/Output	
				SEG16	O	LCD Segment Signal Output	
30	-	-	-	PC10*	IOUDS	PORT C Bit 10 Input/Output	
				SEG15	O	LCD Segment Signal Output	
31	-	-	-	PC11*	IOUDS	PORT C Bit 11 Input/Output	
				SEG14	O	LCD Segment Signal Output	
32	-	-	-	PC12*	IOUDS	PORT C Bit 12 Input/Output	
				SEG13	O	LCD Segment Signal Output	
33	25	17	16	PD0*	IOUDS	PORT D Bit 0 Input/Output	
				SEG12	O	LCD Segment Signal Output	
				SCL0	I/O	I2C Clock Input/Output	
34	26	18	17	PD1*	IOUDS	PORT D Bit 1 Input/Output	
				SEG11	O	LCD Segment Signal Output	
				SDA0	I/O	I2C Data Input/Output	

Table 3. Pin Description (continued)

Pin number				Pin name	Type	Description	Remark
LQFP-80	LQFP-64	LQFP-48	MQFP-44				
35	27	19	18	PD2*	IOUDS	PORT D Bit 2 Input/Output	
				SEG10	O	LCD Segment Signal Output	
				TXD11	O	UART Data Output	
				MOSI11	I/O	SPI Master Output, Slave Input	
36	28	20	19	PD3*	IOUDS	PORT D Bit 3 Input/Output	
				SEG9	O	LCD Segment Signal Output	
				RXD11	I	UART Data Input	
				MISO11	I/O	SPI Master Input, Slave Output	
37	29	21	20	PD4*	IOUDS	PORT D Bit 4 Input/Output	
				SEG8	O	LCD Segment Signal Output	
				SCK11	I/O	SPI Clock Input/Output	
38	30	22	21	PD5*	IOUDS	PORT D Bit 5 Input/Output	
				SEG7	O	LCD Segment Signal Output	
				SS11	I	SPI Slave Select Input	
39	31	23	-	PD6*	IOUDS	PORT D Bit 6 Input/Output	
				SEG6	O	LCD Segment Signal Output	
				EC11	I	Timer 11 Event Count Input	
40	32	24	-	PD7*	IOUDS	PORT D Bit 7 Input/Output	
				SEG5	O	LCD Segment Signal Output	
				EC10	I	Timer 10 Event Count Input	
41	33	25	22	PE7*	IOUDS	PORT E Bit 7 Input/Output	
				COM7	O	LCD Common Signal Output	
				SEG4	O	LCD Segment Signal Output	
				T11OUT	O	Timer 11 Pulse Output	
				T11CAP	I	Timer 11 Capture Input	
42	34	26	23	PE6*	IOUDS	PORT E Bit 6 Input/Output	
				COM6	O	LCD Common Signal Output	
				SEG3	O	LCD Segment Signal Output	
				T10OUT	O	Timer 10 Pulse Output	
				T10CAP	I	Timer 10 Capture Input	
43	35	27	24	PE5*	IOUDS	PORT E Bit 5 Input/Output	
				COM5	O	LCD Common Signal Output	
				SEG2	O	LCD Segment Signal Output	
				PWM30CB	O	Timer 30 PWM Output	
44	36	28	25	PE4*	IOUDS	PORT E Bit 4 Input/Output	
				COM4	O	LCD Common Signal Output	
				SEG1	O	LCD Segment Signal Output	
				PWM30CA	O	Timer 30 PWM Output	

Table 3. Pin Description (continued)

Pin number				Pin name	Type	Description	Remark
LQFP-80	LQFP-64	LQFP-48	MQFP-44				
45	37	29	26	PE3*	IOUDS	PORT E Bit 3 Input/Output	
				COM3	O	LCD Common Signal Output	
				SEG0	O	LCD Segment Signal Output	
				PWM30BB	O	Timer 30 PWM Output	
46	38	30	27	PE2*	IOUDS	PORT E Bit 2 Input/Output	
				COM2	O	LCD Common Signal Output	
				PWM30BA	O	Timer 30 PWM Output	
47	39	31	28	PE1*	IOUDS	PORT E Bit 1 Input/Output	
				COM1	O	LCD Common Signal Output	
				PWM30AB	O	Timer 30 PWM Output	
48	40	32	29	PE0*	IOUDS	PORT E Bit 0 Input/Output	
				COM0	O	LCD Common Signal Output	
				PWM30AA	O	Timer 30 PWM Output	
49	-	-	-	PE15*	IOUDS	PORT E Bit 15 Input/Output	
				SS12	I	SPI Slave Select Input	
50	-	-	-	PE14*	IOUDS	PORT E Bit 14 Input/Output	
				SCK12	I/O	SPI clock input/output	
51	-	-	-	PE13*	IOUDS	PORT E Bit 13 Input/Output	
				RXD12	I	UART Data Input	
				MISO12	I/O	SPI master input, slave output	
52	-	-	-	PE12*	IOUDS	PORT E Bit 12 Input/Output	
				TXD12	O	UART Data Output	
				MOSI12	I/O	SPI master output, slave input	
53	41	-	-	PE11*	IOUDS	PORT E Bit 11 Input/Output	
				SS13	I	SPI Slave Select Input	
54	42	-	-	PE10*	IOUDS	PORT E Bit 10 Input/Output	
				SCK13	I/O	SPI clock input/output	
55	43	-	-	PE9*	IOUDS	PORT E Bit 9 Input/Output	
				RXD13	I	UART Data Input	
				MISO13	I/O	SPI master input, slave output	
56	44	-	-	PE8*	IOUDS	PORT E Bit 8 Input/Output	
				TXD13	O	UART Data Output	
				MOSI13	I/O	SPI master output, slave input	
57	45	33	30	PF7*	IOUDS	PORT F Bit 7 Input/Output	
				T30CAP	I	Timer 30 Capture Input	
58	46	34	31	PF6*	IOUDS	PORT F Bit 6 Input/Output	
				EC30	I	Timer 30 Event Count Input	
59	47	35	32	PF5*	IOUDS	PORT F Bit 5 Input/Output	
				BLNK	I	External Sync Signal Input for T30 PWM	

Table 3. Pin Description (continued)

Pin number				Pin name	Type	Description	Remark
LQFP-80	LQFP-64	LQFP-48	MQFP-44				
60	48	36	33	PF4*	IOUDS	PORT F Bit 4 Input/Output	
				CLKO	O	System Clock Output	
61	-	-	-	PF11*	IOUDS	PORT F Bit 11 Input/Output	
				T14OUT	O	Timer 14 Pulse Output	
				T14CAP	I	Timer 14 Capture Input	
62	-	-	-	PF10*	IOUDS	PORT F Bit 10 Input/Output	
				T13OUT	O	Timer 13 Pulse Output	
				T13CAP	I	Timer 13 Capture Input	
63	-	-	-	PF9*	IOUDS	PORT F Bit 9 Input/Output	
				EC14	I	Timer 14 Event Count Input	
64	-	-	-	PF8*	IOUDS	PORT F Bit 8 Input/Output	
				EC13	I	Timer 13 Event Count Input	
65	49	37	34	PF3*	IOUDS	PORT F Bit 3 Input/Output	
				SXOUT	O	Sub Oscillator Output	
66	50	38	35	PF2*	IOUDS	PORT F Bit 2 Input/Output	
				SXIN	I	Sub Oscillator Input	
67	51	39	36	nRESET	Input	External Reset Input	Pull-up
68	52	40	37	PF1*	IOUDS	PORT F Bit 1 Input/Output	
				XIN	I	Main Oscillator Input	
				(SDA1)	I/O	I2C Data Input/Output	
69	53	41	38	PF0*	IOUDS	PORT F Bit 0 Input/Output	
				XOUT	O	Main Oscillator Output	
				(SCL1)	I/O	I2C Clock Input/Output	
70	54	42	39	VSS	P	Ground	
71	55	43	40	VDD	P	VDD	
72	56	-	-	PA8*	IOUDS	PORT A Bit 8 Input/Output	
				AN11	IA	A/D Converter Analog Input 11	
73	57	-	-	PA9*	IOUDS	PORT A Bit 9 Input/Output	
				AN12	IA	A/D Converter Analog Input 12	
74	58	-	-	PA10*	IOUDS	PORT A Bit 10 Input/Output	
				AN13	IA	A/D Converter Analog Input 13	
75	59	-	-	PA11*	IOUDS	PORT A Bit 11 Input/Output	
76	60	44	41	PA0*	IOUDS	PORT A Bit 0 Input/Output	
				AN0	IA	A/D Converter Analog Input 0	
				SDA1	I/O	I2C Data Input/Output	
77	61	45	42	PA1*	IOUDS	PORT A Bit 1 Input/Output	
				AN1	IA	A/D Converter Analog Input 1	
				SCL1	I/O	I2C Clock Input/Output	

Table 3. Pin Description (continued)

Pin number				Pin name	Type	Description	Remark
LQFP-80	LQFP-64	LQFP-48	MQFP-44				
78	62	46	43	PA2*	IOUDS	PORT A Bit 2 Input/Output	
				AN2	IA	A/D Converter Analog Input 2	
				EC12	I	Timer 12 Event Count Input	
79	63	47	-	PA3*	IOUDS	PORT A Bit 3 Input/Output	
				AN3	IA	A/D Converter Analog Input 3	
80	64	48	-	PA4*	IOUDS	PORT A Bit 4 Input/Output	
				AN4	IA	A/D Converter Analog Input 4	

NOTES:

- *Notation: I=Input, O=Output, U=Pull-up, D=Pull-down, S=Schmitt-Trigger Input Type, C=CMOS Input Type, A=Analog, P=Power
- (*) Selected pin function after reset condition
- Pin order may be changed with revision notice.

3 System and memory overview

Main system and memory of A31G12x series consist of the followings:

- ARM[®] Cortex[®]-M0+ core
- Internal SRAM
- Internal Flash memory
- AHB (Advanced High Performance Bus) and APB (Advanced Peripheral Bus)

3.1 Cortex[®]-M0+ core

The Cortex-M0+ processor is the most energy-efficient ARM processor available. It builds on the very successful Cortex-M0+ processor, retaining full instruction set and tool compatibility, while further reducing energy consumption and increasing performance.

Please refer to the technical reference manual “ARM DDI 0484C” provided by ARM for detail information of Cortex-M0+.

3.2 Interrupt controller

The Cortex-M0+ process has embedded an interrupt controller named NVIC (Nested Vector Interrupt Controller). A31G12x series has additional interrupt control block for controlling 32 interrupt sources generated by internal peripherals.

To use interrupts from internal peripherals, both the NVIC and the interrupt control block must be configured properly. This document describes only the peripheral interrupt controller. For more information about NVIC inside the Cortex-M0+ processor, please refer to the technical reference manual “ARM DDI 0484C” in ARM technical document site.

Table 4. Interrupt Vector Map

Priority	Vector Address	Interrupt Source
-16	0x0000_0000	Stack Pointer
-15	0x0000_0004	Reset Address
-14	0x0000_0008	NMI Exception
-13	0x0000_000C	Hard Fault Exception
-12	0x0000_0010	Reserved
-11	0x0000_0014	
-10	0x0000_0018	
-9	0x0000_001C	
-8	0x0000_0020	
-7	0x0000_0024	
-6	0x0000_0028	

Table 4. Interrupt Vector Map (continued)

Priority	Vector Address	Interrupt Source
-5	0x0000_002C	SVCAll Exception
-4	0x0000_0030	Reserved
-3	0x0000_0034	
-2	0x0000_0038	PenSV Exception
-1	0x0000_003C	SysTick Exception
0	0x0000_0040	LVI Interrupt
1	0x0000_0044	WUT Interrupt
2	0x0000_0048	WDT Interrupt
3	0x0000_004C	EINT0 Interrupt
4	0x0000_0050	EINT1 Interrupt
5	0x0000_0054	EINT2 Interrupt
6	0x0000_0058	EINT3 Interrupt
7	0x0000_005C	TIMER10 Interrupt
8	0x0000_0060	TIMER11 Interrupt
9	0x0000_0064	TIMER12 Interrupt
10	0x0000_0068	I2C0 Interrupt
11	0x0000_006C	USART10 Interrupt
12	0x0000_0070	WT Interrupt
13	0x0000_0074	TIMER30 Interrupt
14	0x0000_0078	I2C1 Interrupt
15	0x0000_007C	TIMER20 Interrupt
16	0x0000_0080	TIMER21 Interrupt
17	0x0000_0084	USART11 Interrupt
18	0x0000_0088	ADC Interrupt
19	0x0000_008C	UART0 Interrupt
20	0x0000_0090	UART1 Interrupt

Table 4. Interrupt Vector Map (continued)

Priority	Vector Address	Interrupt Source
21	0x0000_0094	TIMER13 Interrupt
22	0x0000_0098	TIMER14 Interrupt
23	0x0000_009C	TIMER15 Interrupt
24	0x0000_00A0	TIMER16 Interrupt
25	0x0000_00A4	I2C2 Interrupt
26	0x0000_00A8	USART12 Interrupt
27	0x0000_00AC	USART13 Interrupt
28	0x0000_00B0	Reserved
29	0x0000_00B4	
30	0x0000_00B8	
31	0x0000_00BC	

3.3 Boot mode

3.3.1 Boot mode pins

A31G12x series has a Boot mode to program the internal flash memory. The Boot mode will be activated by setting a BOOT pin to “Low” level at reset timing (Normal operation mode is “High” level).

The Boot mode supports either UART boot or SPI boot. For the UART boot, TXD10/RXD10 ports are used. For the SPI boot, MOSI10/MISO10/SCK10/SS10 ports are used.

Table 5 introduces pins used in the Boot mode.

Table 5. Boot Mode Pin List

Block	Pin Name	Direction	Description
SYSTEM	nRESET	I	Reset Input signal
	BOOT/PB3	I	'0' to enter Boot mode
UART mode of USART10	RXD10/PB1	I	UART Boot Receive Data
	TXD10/PB0	O	UART Boot Transmit Data
SPI mode of USART10	SS10/PB3	I	SPI Boot Slave Selectable after Boot ROM
	SCK10/PB2	I	SPI Boot Clock Input
	MISO10/PB1	I	SPI Boot Data Input with function exchange
	MOSI10/PB0	O	SPI Boot Data Output with function exchange

3.3.2 Boot mode connection

A user can design target boards using any of Boot mode ports – UART or SPI mode of USART10. Examples of connection diagrams in the Boot mode are introduced in figures 6 and 7.

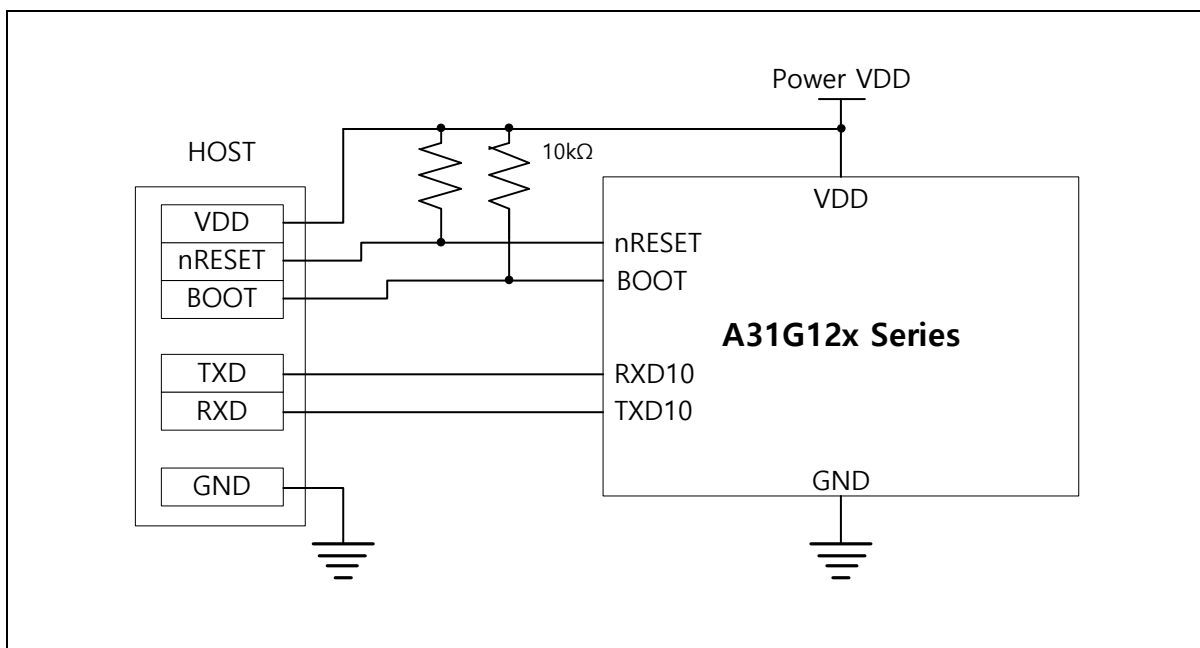

Figure 6. Connection Diagram of UART Boot

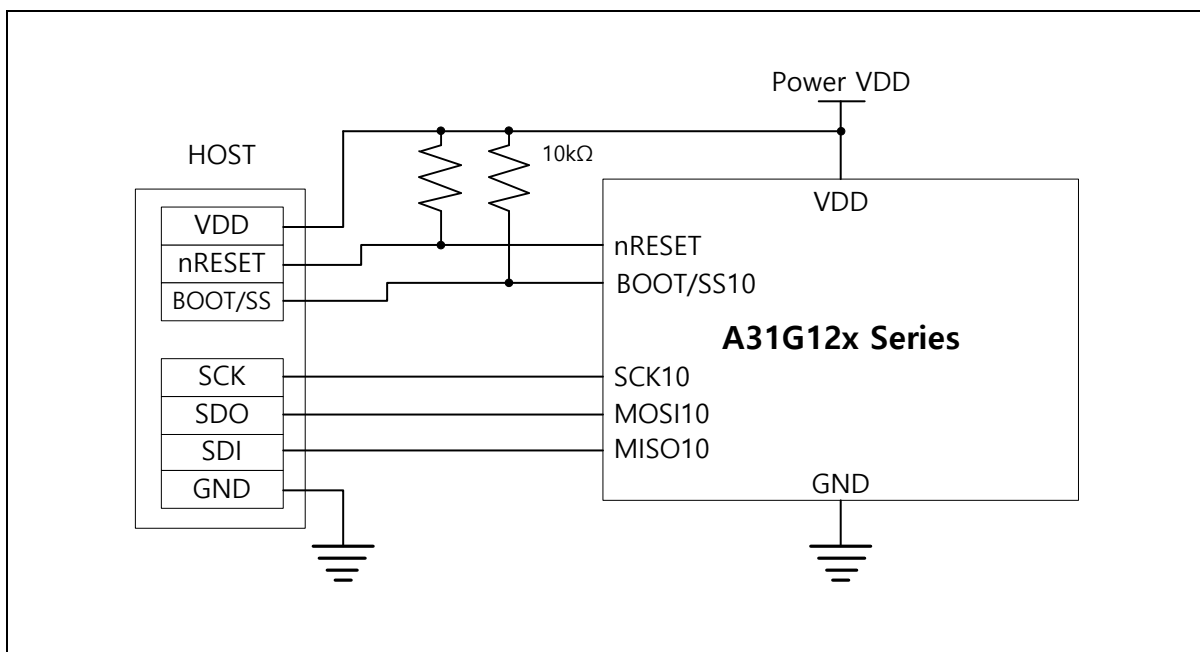

Figure 7. Connection Diagram of SPI Boot

3.4 Memory organization

3.4.1 Memory map

Figure 8 shows addressable memory space in memory map.

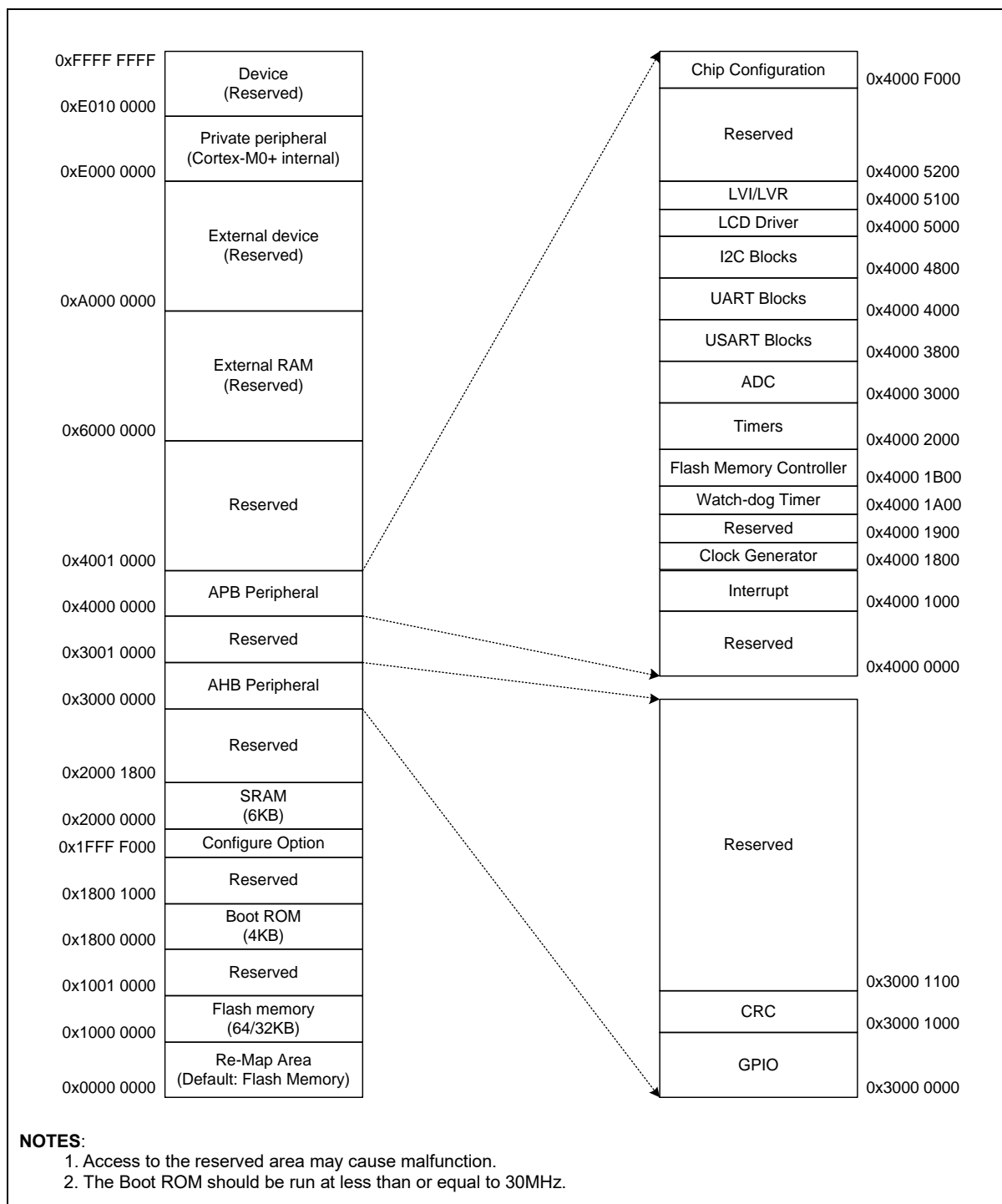

Figure 8. Main Memory Map

3.4.2 Internal SRAM

A31G12x series has a block of 0-wait on-chip SRAM. Its size is 6KB, and its base address is 0x2000_0000. The SRAM's memory area is mainly for data memory and stack memory. It is possible to locate code area in the SRAM memory for fast operation or for flash erase or program operation for self-program.

This device does not support memory remapping. So jump and return is required to process the code in SRAM memory area.

3.4.3 Flash memory

A31G12x series has an internal flash memory featuring the followings:

- 64KB or 32KB Flash code memory
- 32-bit read data bus width
- 128-byte page size
- Page erase and bulk erase available
- 128-byte unit program

Table 6. Internal Flash Memory Specification

Item	Description
Size	64KB
Start address	0x1000_0000
End address	0x1000_FFFF
Page size	128-byte
Total page count	512 pages
PGM unit	128-byte
Erase unit	128-byte or bulk

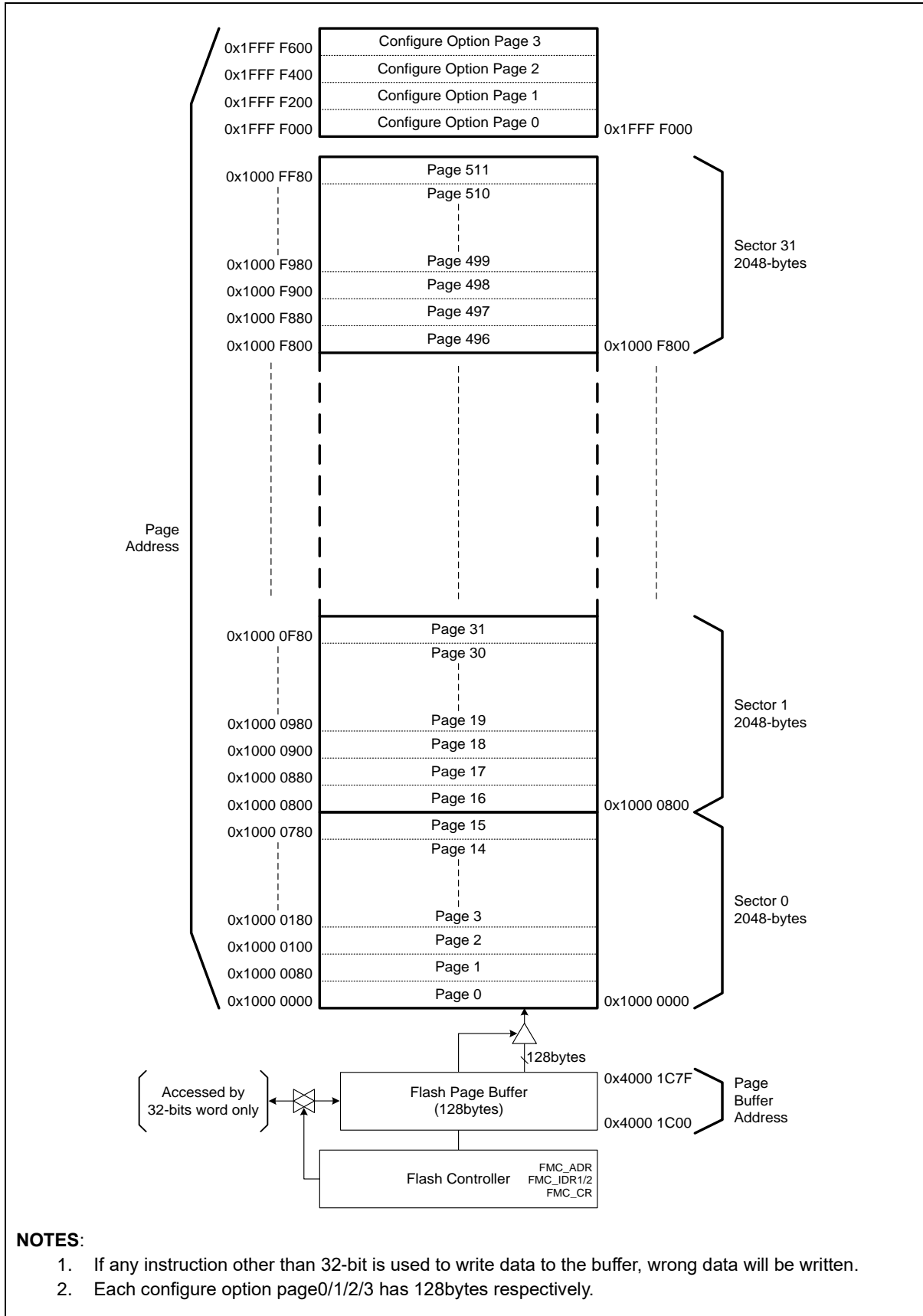

NOTES:

1. If any instruction other than 32-bit is used to write data to the buffer, wrong data will be written.
2. Each configure option page0/1/2/3 has 128bytes respectively.

Figure 9. Internal Flash Memory Block Diagram

3.4.4 Configure option area

Configuration option area of A31G12x series is used for system related trimming values, user option, and user data. The configure option area consists of four pages in the flash memory, which can be erased and written by the flash memory controller. This area can be read by any instruction.

The four pages of the configuration option area are listed in the followings:

- Page 0: System related trimming values
- Page 1: User option for read protection, watchdog timer, and LVR voltage level configurations
- Page 2: User data 0 area
- Page 3: User data 1 area

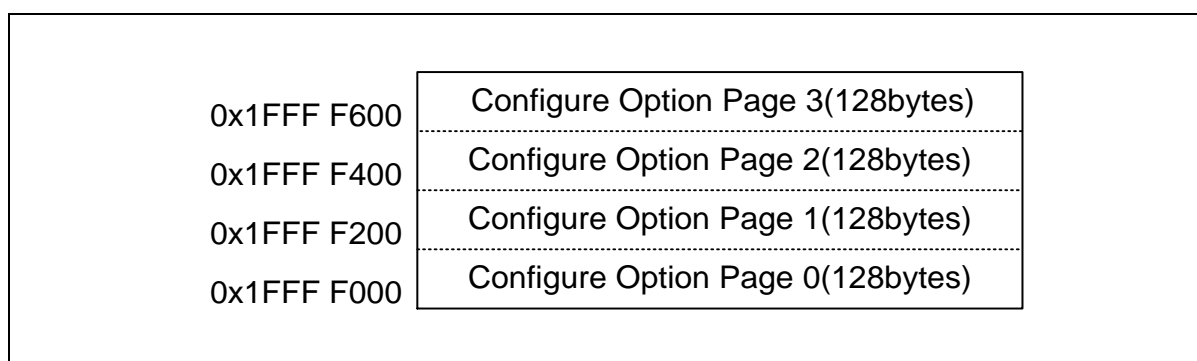

Figure 10. Configure Option Area Structure

3.4.5 Configuration option page

Base address of the configuration option area ranges from 0x1FFF_F000 to 0x1FFF_F600. The area map is shown in Table 7.

Table 7. Configuration Option Area Map

Page	NAME	ADDRESS	DESCRIPTION
0	-	0x1FFF_F000 to 0x1FFF_F07F	System Trimming Values
1	CONF_RPCNFIG	0x1FFF_F200	Configuration for Read Protection
	CONF_WDTCNFIG	0x1FFF_F20C	Configuration for Watch-Dog Timer
	CONF_LVRCNFIG	0x1FFF_F210	Configuration for Low Voltage Reset
	CONF_CNFIGWTP1	0x1FFF_F214	Erase/Write Protection for Configure Option Page 1/2/3
	CONF_FMWTP1	0x1FFF_F240	Erase/Write Protection for Flash Memory
2	-	0x1FFF_F400 to 0x1FFF_F47F	User Data Area 0
3	-	0x1FFF_F600 to 0x1FFF_F67F	User Data Area 1

4 SCU (System Control Unit)

A31G12x series has a built-in intelligent power control block, which manages analog blocks and operating modes. Internal reset and clock signals are controlled by SCU block to maintain optimized system performance and power dissipation.

4.1 SCU block diagram

Figure 11 shows the SCU block diagram.

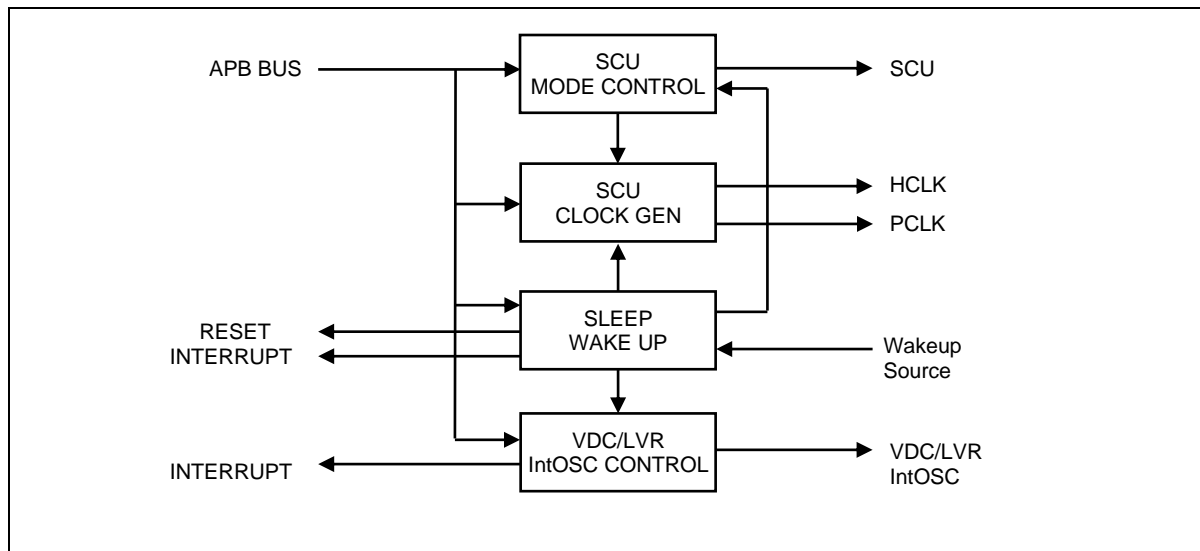

Figure 11. SCU Block Diagram

4.2 Clock system

A31G12x series has two main operating clocks. One is HCLK, which supplies the clock to the CPU and AHB bus system. The other one is PCLK, which supplies the clock to the peripheral systems.

Users can control the clock system variation by software. Figure 12 shows the clock system of A31G12x series and Table 8 shows the descriptions for clock sources.

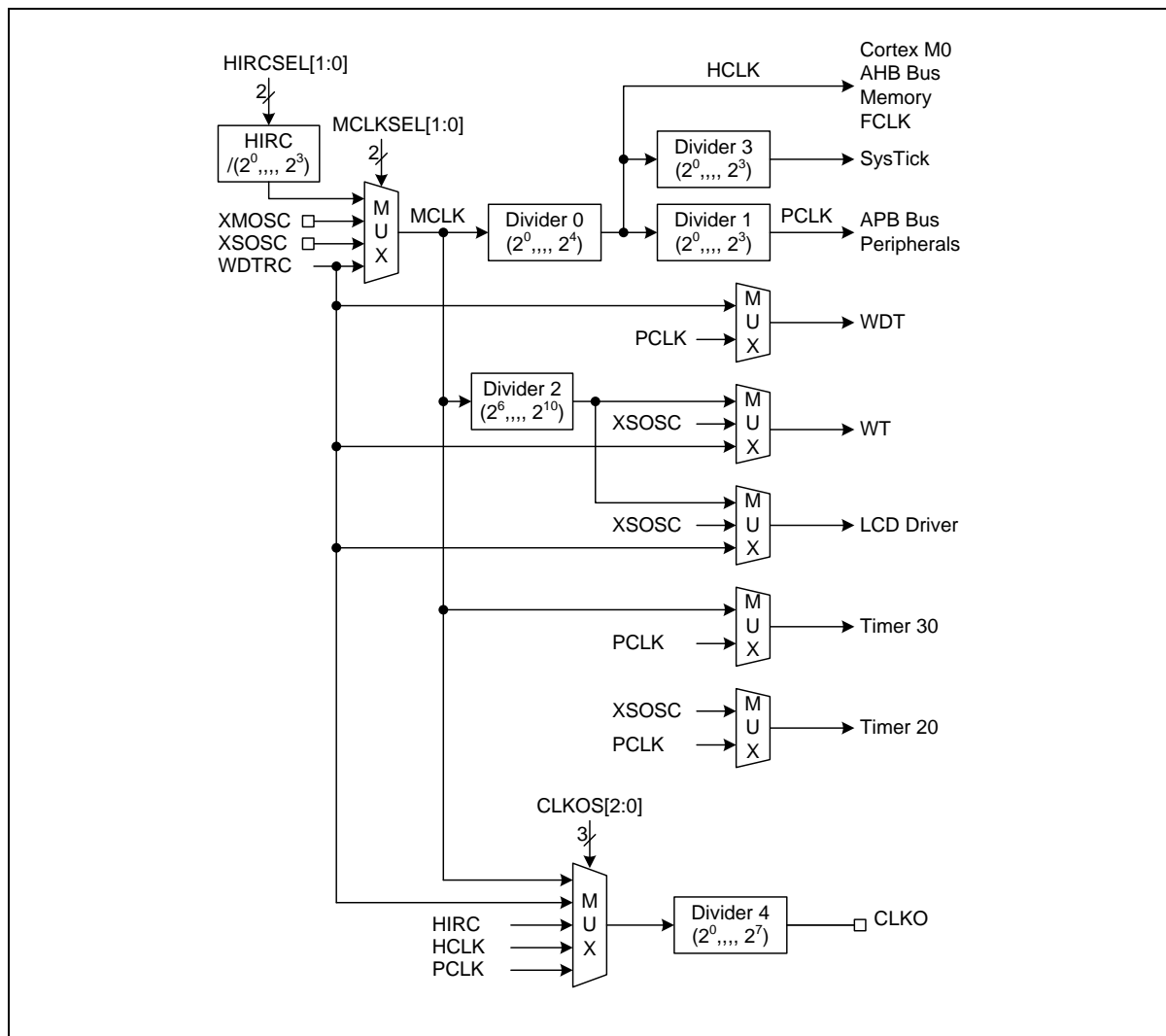

Figure 12. Clock Source Configuration

Each mux to switch clock source has a glitch-free circuit. So a clock can be switched without glitch risks. When you change the clock mux control, be sure both clock sources are alive. If either is not alive, clock change operation stops and system will shut down and not recover.

Table 8. Clock Sources

Clock name	Mnemonic	Frequency	Description
Main OSC	XMOSC	<ul style="list-style-type: none"> X-TAL (2MHz to 16MHz) External Clock (2MHz to 40MHz) 	<ul style="list-style-type: none"> External Main Crystal OSC External Main Clock
Sub OSC	XSOSC	X-TAL (32.768kHz)	External Sub Crystal OSC
Internal RC OSC	HIRC	2.5MHz to 40MHz	High Frequency Internal RC OSC
WDT RC OSC	WDTRC	40kHz	Watchdog Timer RC OSC

4.2.1 HCLK clock domain

HCLK clock feeds the clock to the CPU and AHB bus. Cortex-M0+ CPU requires 2 clocks, FCLK and HCLK. FCLK is a free running clock and is always running except during power down mode. HCLK can be stopped during sleep mode.

The HCLK clock operates the BUS system and memory systems. Max BUS operating clock speed is 40MHz. HCLK frequency should be limited to a frequency of 40MHz or lower.

4.2.2 Miscellaneous clock domain

Various clock sources are required for each functional block. The SCU provides clock source selectivity with dedicated pre-scaler for each functional block. The clock selection mux does not support glitch-free function, so the clock is unpredictable during clock selection. Figure 13 shows the configurations for miscellaneous clocks.

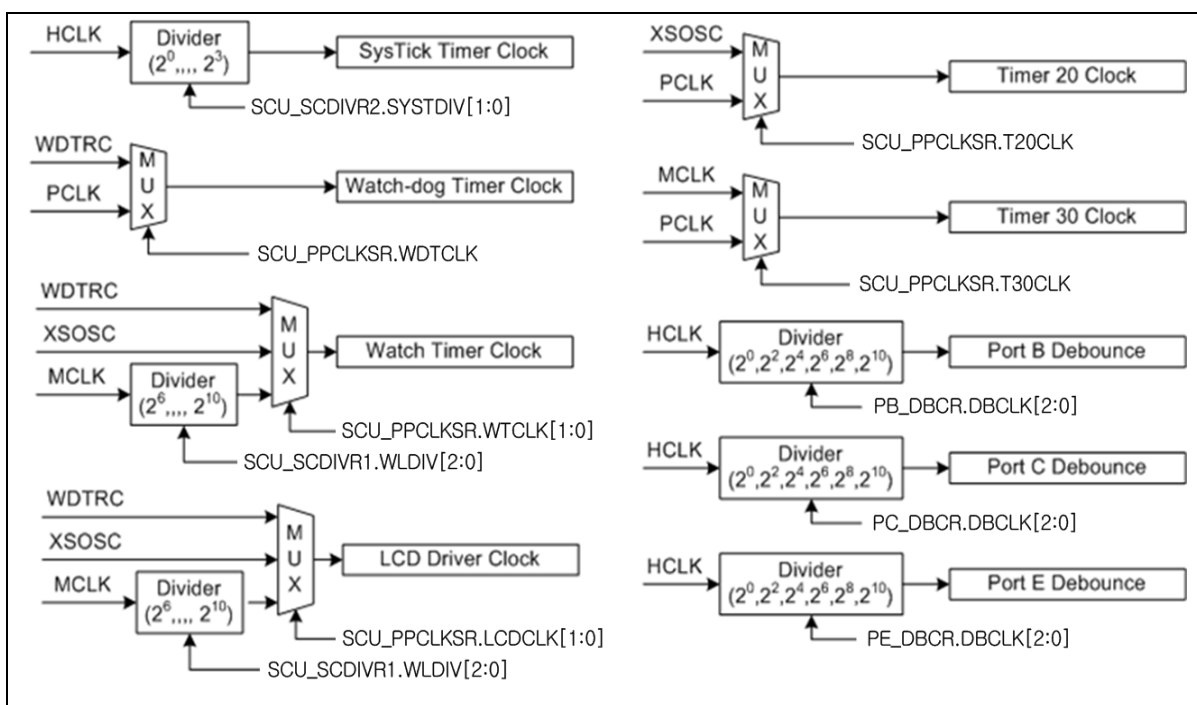

Figure 13. Miscellaneous Clock Configuration

4.2.3 PCLK clock domain

PCLK is the master clock for all the peripherals except for the CRC generator and ports. It can shut down during power down mode. Each peripheral clock is generated by SCU_PPCLKEN1 and SCU_PPCLKEN2 register set. Figure 12 illustrates the PCLK clock distributions. The peripherals are not accessible even by reading its registers until each PCLK clock of each block is enabled.

4.2.4 Clock configuration procedure

After power on the device, a default system clock is generated by HIRC (2.5MHz) clock. The HIRC is enabled by default during power up sequence. Other clock sources are enabled by user controls and configuration options with a system clock.

XMOSC and XSOSC clocks are enabled by XMOSCEN and XSOSCEN bits of SCU_CLKSRCR register respectively. Before enabling XMOSC and XSOSC blocks, the pin mux configuration should be set for XIN/XOUT and SXIN/SXOUT functions. PF0/PF1 and PF2/PF3 pins are shared by XMOSC's XIN/XOUT function and XSOSC's SXIN/SXOUT function – PF_MOD and PF_AFSR1 registers should be configured properly.

After enabling the XMOSC and XSOSC blocks, a user can check stability of crystal oscillation through a clock monitoring control register, SCU_CMONCR. It takes more than 1ms to ensure stable crystal oscillation before changing the system clock.

Figure 14 shows an example flow chart to configure the system clock to XMOSC and XSOSC clock.

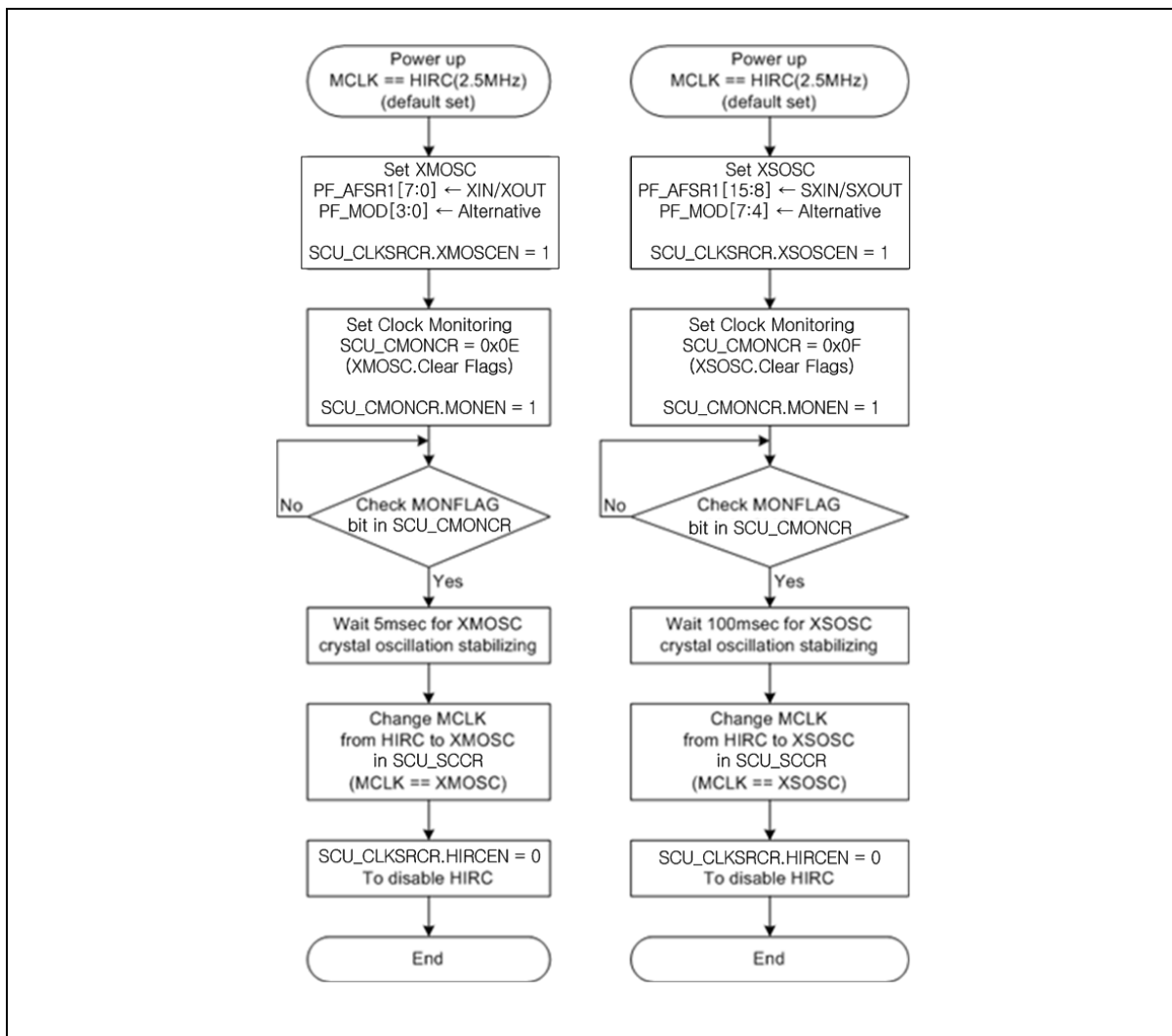

Figure 14. Clock Configuration Procedure

4.3 Reset

A31G12x series has two system resets. One is the cold reset by POR, which is effective during power up or down sequence. The other is the warm reset, generated by several reset sources. The reset event makes the device to turn back to its initial state.

The cold reset has only one reset source, which is POR, while the warm reset has several reset sources as shown below:

- nRESET pin
- WDT reset
- LVR reset
- MON reset
- S/W reset
- CPU request reset

4.3.1 Cold reset

The cold reset is one of important feature of the A31G12x series when it powers up. This characteristic will globally affect the system boot.

Internal VDC is enabled when VDD power is turned on. Internal VDD level slope follows the External VDD power slope. Internal POR trigger level is at 1.2V of the internal VDC voltage. At this time, boot operation begins.

Internal RC clock turns on and counts 4ms for internal VDC level to stabilize. At this time, external VDD voltage level should be bigger than initial LVR level (1.62V). After 4ms of counting, the CPU reset is released and operation begins.

Figure 15 shows waveform of power up sequence and internal reset.

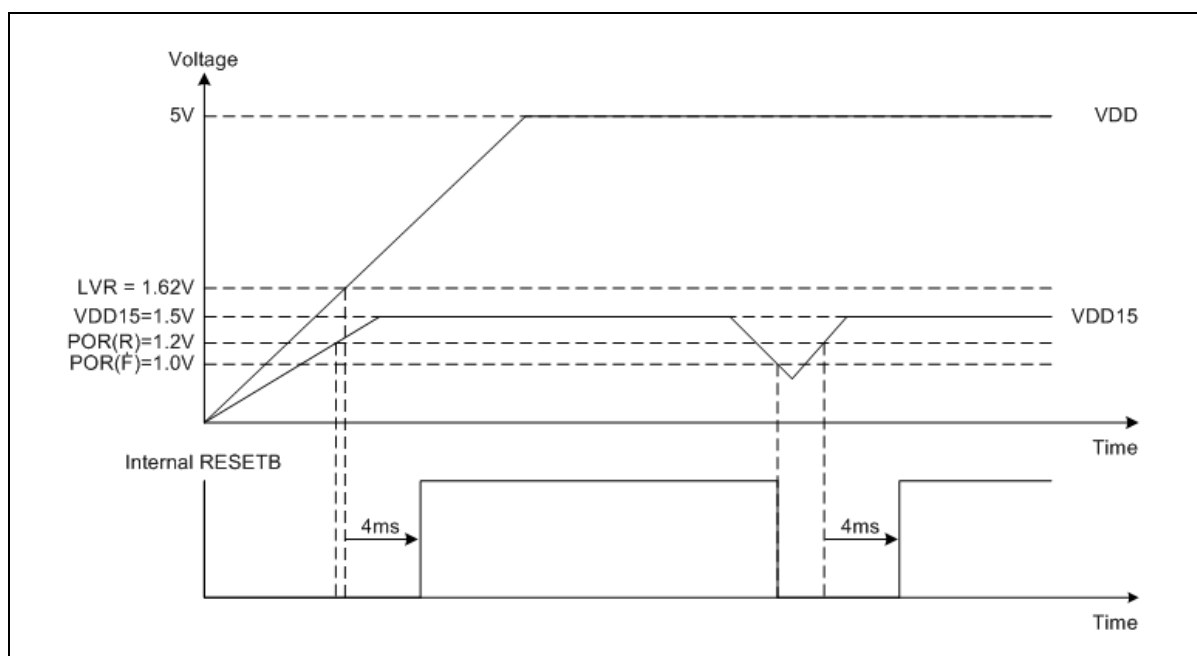

Figure 15. Power-up POR Sequence

A register SCU_RSTSSR shows the POR reset status. The last reset comes from the POR. SCU_RSTSSR.PORSTA is set to '1'. After power on, this bit is always '1' if the bit is not cleared by S/W. If abnormal internal voltage drop is detected during normal operation, the system will be reset and this bit also will be set to '1'.

When the cold reset is applied, the entire device returns to its initial state.

4.3.2 Warm reset

The warm reset event has several reset sources and some parts of the device return to their initial states when the warm reset takes place.

The warm reset status appears in a register SCU_RSTSSR. A reset for each peripheral block is controlled by a register SCU_PPRST. The reset can be masked independently.

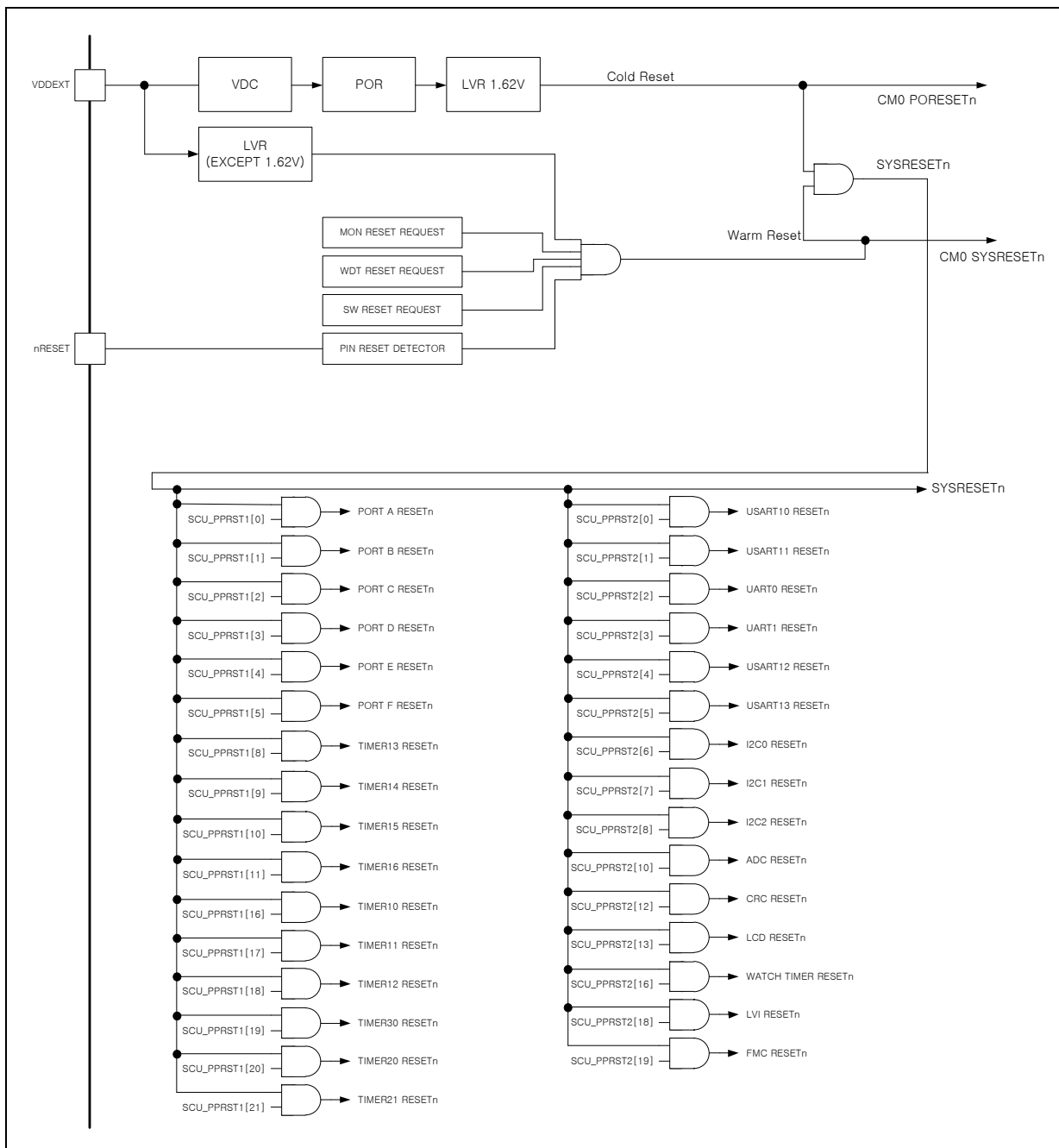

Figure 16. Reset Configuration

4.3.3 LVR reset

The LVR voltage level is set by a low voltage reset configuration register (CONF_LVRCNFIG) in the configuration option page 1.

LVR reset status appears in a register SCU_RSTSSR. The reset for LVR is controlled by a register SCU_LVRCR. The register is cleared to “0x00” on POR reset.

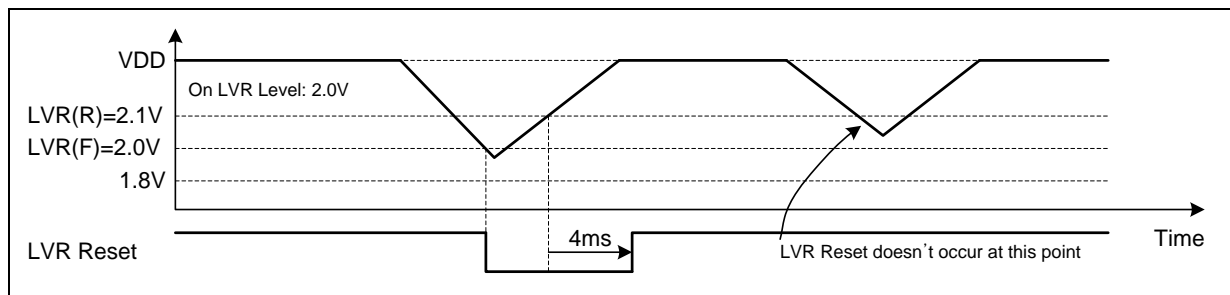

Figure 17. LVR Reset Timing Diagram

4.4 Operation mode

INIT mode is the initial state of the device when reset. At RUN mode, the chip runs at its max CPU performance with a high-speed clock system. At SLEEP and DEEP SLEEP mode, the chip runs at a low power consumption mode. The system saves power by halting the processor core and unused peripherals.

Figure 18 shows the operation mode transition diagram.

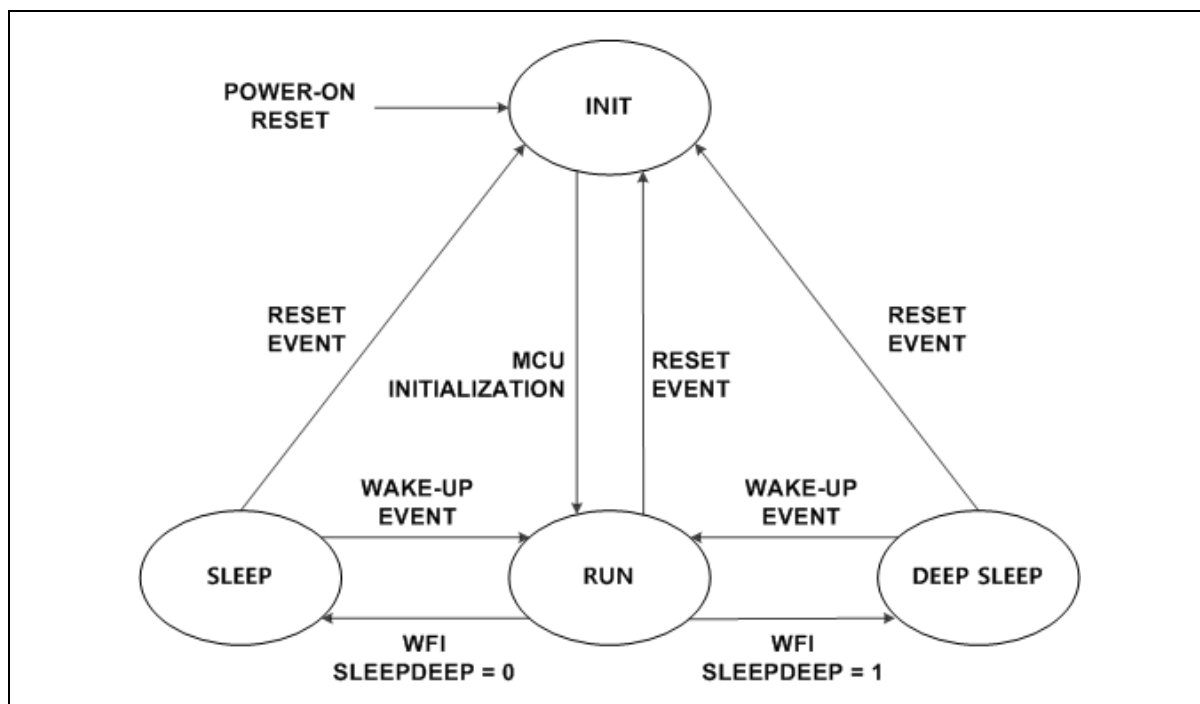

Figure 18. Operating Mode

4.4.1 Run mode

This mode is to operate CPU core and peripheral hardware with a high-speed clock. The device enters in the INIT state after reset, and then enters in the RUN mode.

4.4.2 Sleep mode

The device stops only CPU in this mode. Each peripheral function turns on by a function enable bit and a clock enable bit of the register SCU_PPCLKEN.

4.4.3 Deep sleep mode

The device stops not only CPU but also a selected system clock (MCLK) in this mode. Watch timer with sub clock and watchdog timer with WDTRC still operate in this mode.

Table 9. Functional table on current mode

IP	Main Run (IDD1)	Main Sleep (IDD2)	Sub Run (IDD3)	Sub Sleep (IDD4)	Deep Sleep (IDD5)
CPU	O	X	O	X	X
FLASH	O	X	O	X	X
SRAM	O	X	O	X	X
FMC	Optional	X	Optional	X	X
CRC	Optional	X	Optional	X	X
POR	O	O	O	O	O
LVR/LVI	Optional	Optional	Optional	Optional	Optional
GPIO	Optional	Optional	Optional	Optional	Optional
SCU	O	O	O	O	O
I2C	Optional	Optional	Optional	Optional	X
USART	Optional	Optional	Optional	Optional	Optional
UART	Optional	Optional	Optional	Optional	X
SysTick	Optional	Optional	Optional	Optional	X
T10 – T16	Optional	Optional	Optional	Optional	X
T20	Optional	Optional	Optional	Optional	Optional
T21	Optional	Optional	Optional	Optional	X
T30	Optional	Optional	Optional	Optional	X
WDT	Optional	Optional	Optional	Optional	Optional ^{NOTE3}
WUT	O	O	O	O	X
ADC	Optional	Optional	X	X	X
LCD Driver	Optional	Optional	Optional	Optional	Optional
WT	Optional	Optional	Optional	Optional	Optional
HIRC	Optional	Optional	X	X	X
WDTRC	Optional	Optional	Optional	Optional	Optional
XMOSC	Optional	Optional	X	X	X
XSOSC	Optional	Optional	Optional	Optional	Optional

NOTES:

1. O: Enable, X: Disable, Optional: A function can be disabled/enabled by s/w.
2. It can be woken up from sleep and deep sleep modes by an interrupt source of the optional peripherals.
3. The watch-dog timer interrupt source can't be used as a wake-up source in the deep sleep mode. But the watch-dog timer can run in the deep sleep mode.

4.5 Pin description for SCU

Table 10. Pins and External Signals for SCU

PIN NAME	TYPE	DESCRIPTION
nRESET	I	External Reset Input
XIN/XOUT	OSC	External Crystal Oscillator for Main Clock
SXIN/SXOUT	OSC	External Crystal Oscillator for Sub Clock
CLKO	O	Clock Output Monitoring Signal

5 PCU and GPIO

PCU (Port Control Unit) configures and controls external I/Os as shown below:

- It configures direction of an external signal of each pin.
- It sets Interrupt trigger mode for each pin.
- It manages internal pull-up and pull-down register control and open drain control.

Most pins, except for dedicated function pins, can be used as GPIO (General Purpose I/O) ports. The GPIO block controls the GPIO as shown below:

- It selects output signal level (H/L).
- It controls external interrupt interface.
- It enables or disables the pull-ups and the pull-downs.

5.1 PCU and GPIO block diagrams

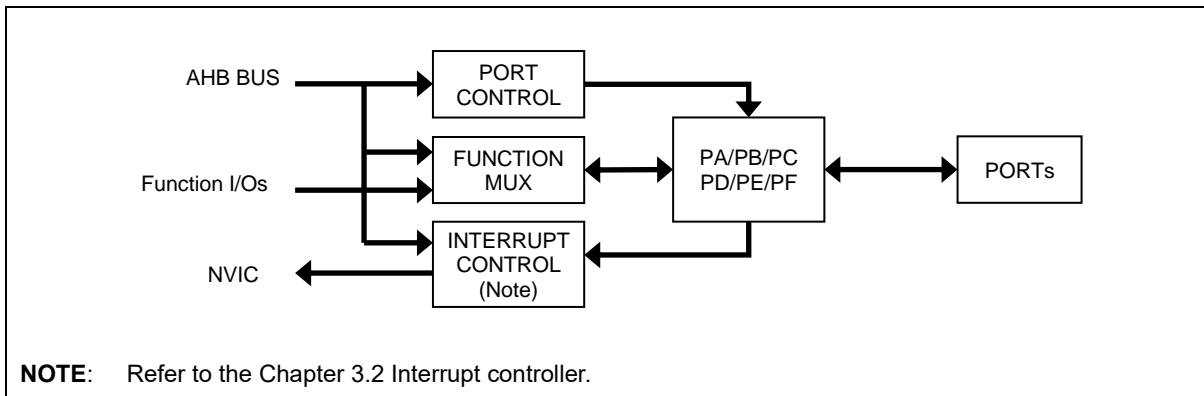

Figure 19. PCU Block Diagram

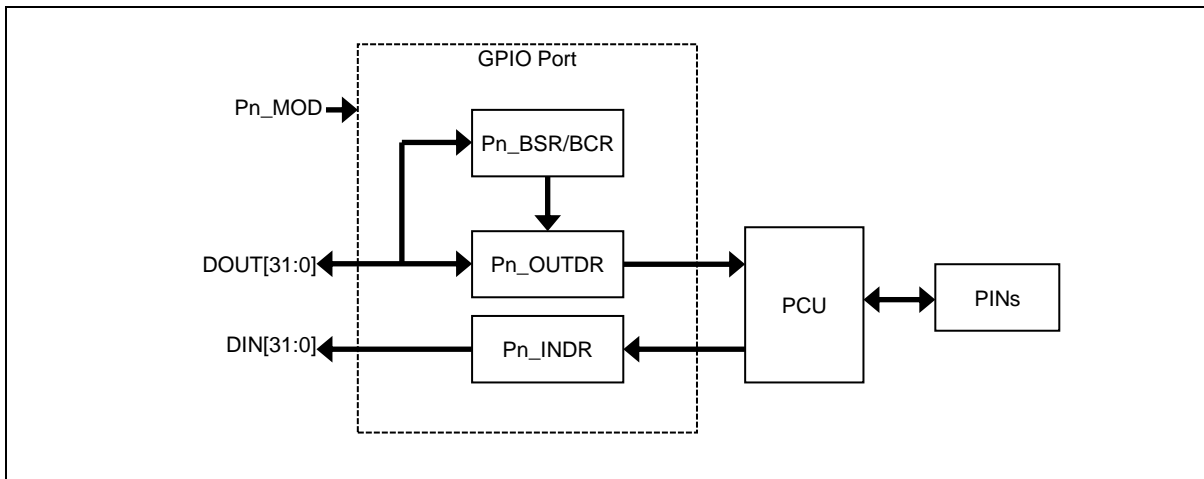

Figure 20. GPIO Block Diagram

5.2 I/O port block diagram

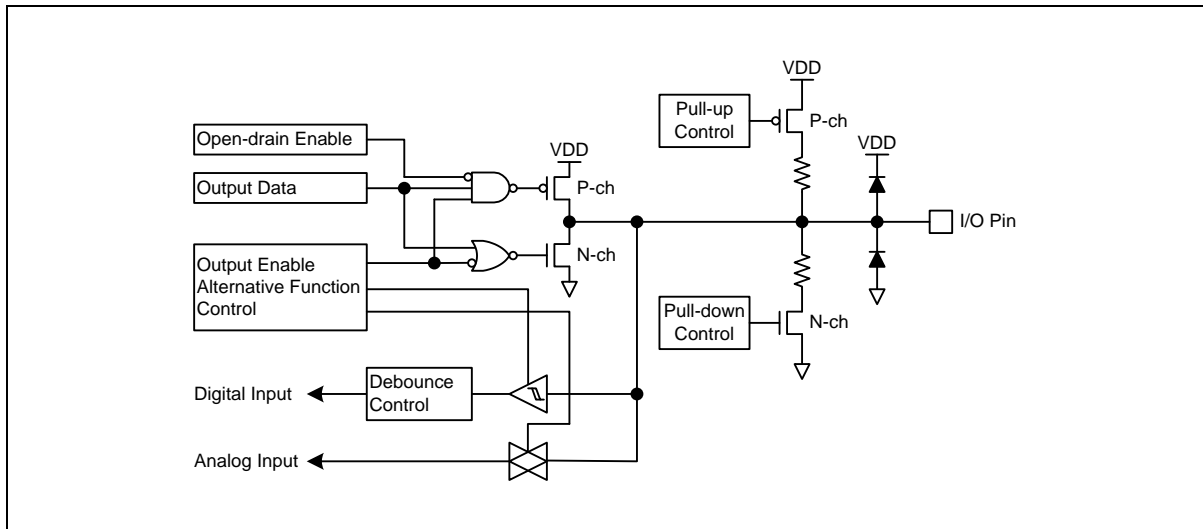

Figure 21. I/O Port Block Diagram (External Interrupt I/O pins)

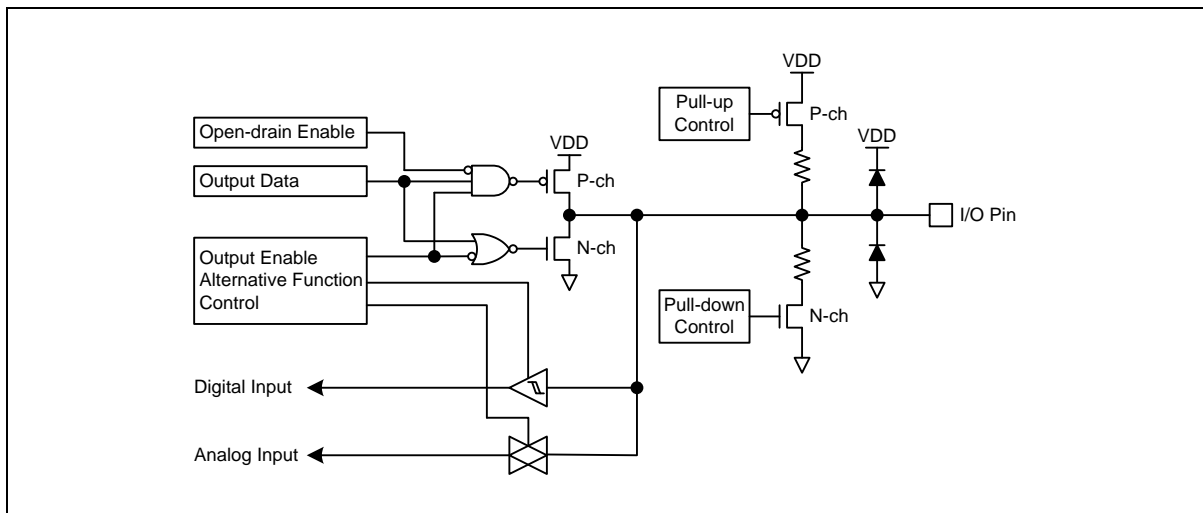

Figure 22. I/O Port Block Diagram (General I/O pins)

5.3 Pin multiplexing

GPIO pins support alternative functions. Table 11 shows pin multiplexing information.

Table 11. GPIO Alternative Functions

PORT	PIN	FUNCTION				
		AF0	AF1	AF2	AF3	AF4
PA	0	–	SDA1	–	AN0	–
	1	–	SCL1	–	AN1	–
	2	–	EC12	–	AN2	–
	3	–	–	–	AN3	–
	4	–	–	–	AN4	–
	5	–	T12OUT	T12CAP	AN5	–
	6	SEG27	–	–	AN6	–
	7	SEG26	–	–	AN7	AVREF
	8	–	–	–	AN11	–
	9	–	–	–	AN12	–
	10	–	–	–	AN13	–
	11	–	–	–	–	–
PB	0	SEG41	TXD10	MOSI10	AN8	–
	1	SEG40	RXD10	MISO10	AN9	–
	2	SEG39	–	SCK10	AN10	–
	3	SEG38	BOOT	SS10	–	–
	4	SEG37	TXD0	SWCLK	–	–
	5	SEG36	RXD0	SWDIO	–	–
	6	SEG35	TXD1	–	–	–
	7	SEG34	RXD1	–	–	–
	8	SEG33	EC16	–	–	–
	9	SEG32	EC15	–	–	–
	10	SEG31	T16OUT	T16CAP	–	–
	11	SEG30	T15OUT	T15CAP	–	–
	12	SEG29	–	–	–	–
	13	SEG28	–	–	–	–
	14	SEG27	–	–	–	–
15	SEG26	–	–	–	–	

Table 11. GPIO Alternative Functions (continued)

PORT	PIN	FUNCTION				
		AF0	AF1	AF2	AF3	AF4
PC	0	SEG25	T20OUT	T20CAP	–	–
	1	SEG24	T21OUT	T21CAP	–	–
	2	SEG23	EC20	–	–	–
	3	SEG22	EC21	–	–	–
	4	SEG21	–	–	–	–
	5	SEG20	SDA2	–	–	–
	6	SEG19	SCL2	–	–	–
	7	SEG18	–	–	–	–
	8	SEG17	–	–	–	–
	9	SEG16	–	–	–	–
	10	SEG15	–	–	–	–
	11	SEG14	–	–	–	–
	12	SEG13	–	–	–	–
PD	0	SEG12	SCL0	–	–	–
	1	SEG11	SDA0	–	–	–
	2	SEG10	TXD11	MOSI11	–	–
	3	SEG9	RXD11	MISO11	–	–
	4	SEG8	–	SCK11	–	–
	5	SEG7	–	SS11	–	–
	6	SEG6	EC11	–	–	–
PE	7	SEG5	EC10	–	–	–
	0	COM0	PWM30AA	–	–	–
	1	COM1	PWM30AB	–	–	–
	2	COM2	PWM30BA	–	–	–
	3	COM3/SEG0	PWM30BB	–	–	–
	4	COM4/SEG1	PWM30CA	–	–	–
	5	COM5/SEG2	PWM30CB	–	–	–
	6	COM6/SEG3	T10OUT	T10CAP	–	–
	7	COM7/SEG4	T11OUT	T11CAP	–	–
	8	–	TXD13	MOSI13	–	–
	9	–	RXD13	MISO13	–	–
	10	–	–	SCK13	–	–
	11	–	–	SS13	–	–
	12	–	TXD12	MOSI12	–	–
	13	–	RXD12	MISO12	–	–
14	–	–	SCK12	–	–	
15	–	–	SS12	–	–	

Table 11. GPIO Alternative Functions (continued)

PORT	PIN	FUNCTION				
		AF0	AF1	AF2	AF3	AF4
PF	0	XOUT	(SCL1)	–	–	–
	1	XIN	(SDA1)	–	–	–
	2	SXIN	–	–	–	–
	3	SXOUT	–	–	–	–
	4	CLKO	–	–	–	–
	5	–	BLNK	–	–	–
	6	–	EC30	–	–	–
	7	–	–	T30CAP	–	–
	8	–	EC13	–	–	–
	9	–	EC14	–	–	–
	10	–	T13OUT	T13CAP	–	–
	11	–	T14OUT	T14CAP	–	–

NOTES:

1. An unused pin shouldn't be configured as an input floating.
2. After reset, the PB3 pin is configured as BOOT alternative function and the internal pull-up is activated.
3. After reset, the PB4 and PB5 pins are configured as SWCLK and SWDIO alternative functions, and the internal pull-down on SWCLK and the internal pull-up on SWDIO are activated.
4. The PE3 – PE7 are automatically configured as common or segment signal according to the duty of the LCD control register when the pins are selected as alternative functions for common/segment.
5. The SWCLK and SWDIO pins shouldn't be changed as other alternative functions by software during the pins are connected with debugger host.

6 WDT

WDT (Watchdog Timer) rapidly detects CPU malfunctions such as endless loops caused by noise and returns the CPU to the normal state. WDT signal for malfunction detection can be used as either a CPU reset or an interrupt request.

When the WDT is not being used for malfunction detection, it can be used as a timer to generate interrupts at fixed intervals. When WDT_CNT value reaches WDT_WINDR value, a watchdog interrupt can be generated. The underflow time of the WDT can be set by WDT_DR. If an underflow occurs, an internal reset may be generated. The WDT operates at 40kHz which is the embedded RC oscillator's clock.

WDT operations are listed in the followings:

- 24-bit down counter (WDT_CNT)
- Reset or periodic interrupt selection
- Count clock selection
- Watchdog overflow output signal
- Counter window function

6.1 WDT block diagram

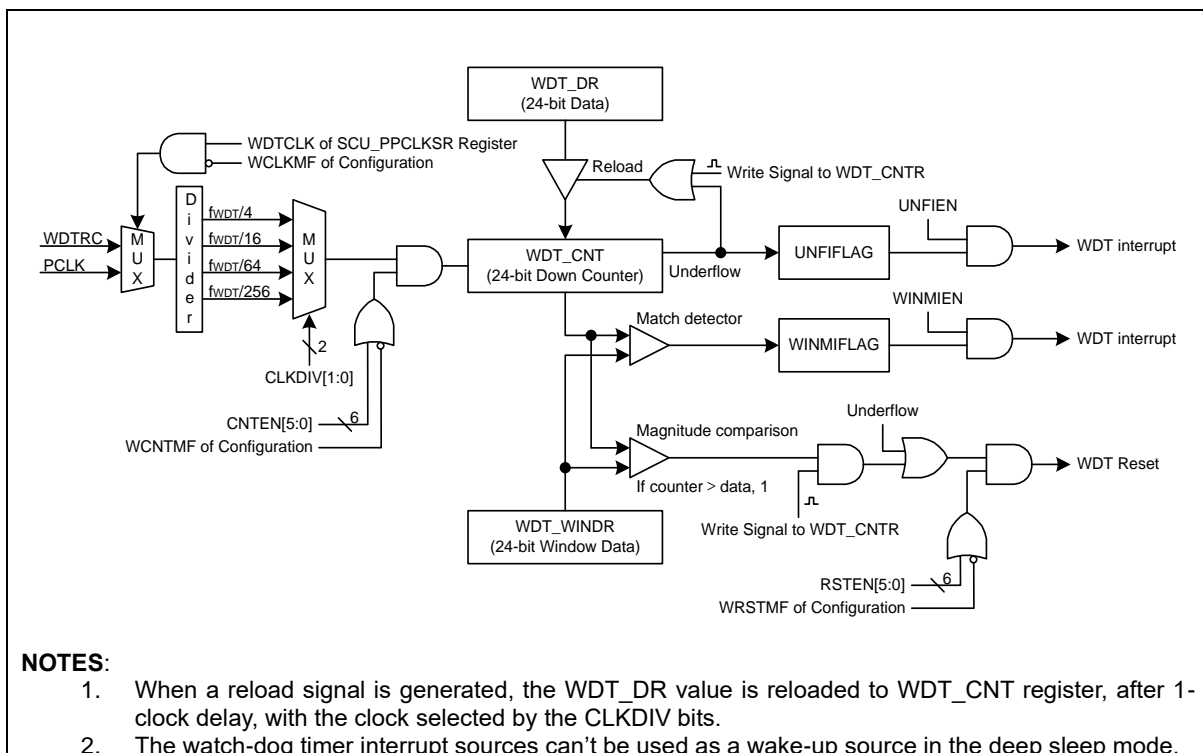

Figure 23. WDT Block Diagram

7 WT

WT (WATCH TIMER) has a function for RTC (Real Time Clock) operation. It is generally used for RTC design. The internal structure of the watch timer consists of the clock source select circuit, timer counter circuit, output select circuit and watch timer control register. To operate the watch timer, determine the input clock source, output interval and set WTEN as '1' in watch timer control register (WT_CR). It is able to operate simultaneously or individually. To stop the WT, clear the WTEN bit in the WT_CR register. Even when the CPU is in STOP mode, sub clock stays alive and the WT can continue operation. The WT_CR can control WT clear and set Interval value at writing, and can read 12-bit WT counter value at reading. The WT features the followings:

- 14-bit Divider
- 12-bit up-counter
- RTC function

7.1 WT block diagram

Figure 24 shows a block diagram of the WT block.

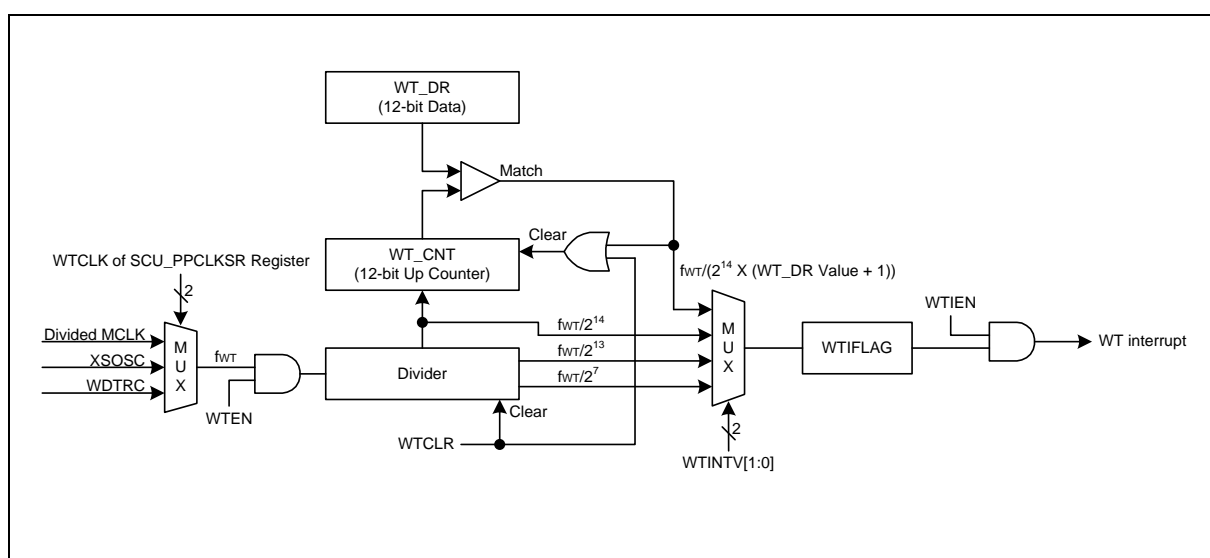

Figure 24. WT Block Diagram

8 Timer counters

8.1 Timer counter 10/11/12/13/14/15/16

The timer block comprises 7 channels of 16-bit general purpose timers. Each has an independent 16-bit counter and a dedicated prescaler that feeds counting clock. They support periodic timer, PWM pulse, one-shot and capture mode.

One more optional free-run timer is provided. The main purpose of this timer is a periodical tick timer or a wake-up source. The timer counter 10/11/12/13/14/15/16 features the followings:

- 16-bit up-counter and 12-bit prescaler
- Periodic timer, One-shot timer, PWM pulse, and Capture mode
- Synchronous start and clear function

8.1.1 Timer counter 10/11/12/13/14/15/16 block diagram

Figure 25 shows the block diagram of a timer block unit.

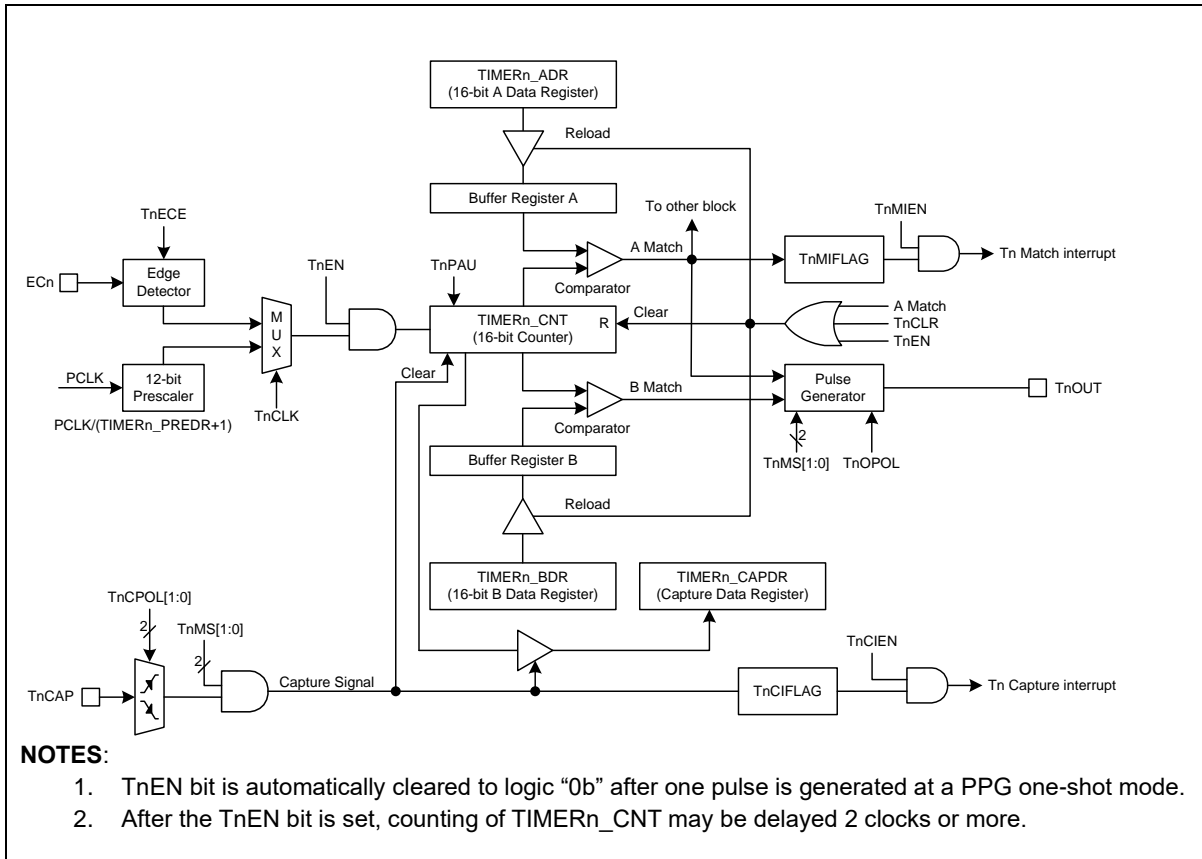

Figure 25. Timer Counter n Block Diagram (n = 10, 11, 12, 13, 14, 15 and 16)

8.1.2 Pin description for timer counter 10/11/12/13/14/15/16

Table 12. Pins and External Signals for Timer Counter n (n = 10, 11, 12, 13, 14, 15 and 16)

PIN NAME	TYPE	DESCRIPTION
Ecn	I	External clock input
TnCAP	I	Capture input
TnOUT	O	PWM/one-shot output

8.2 Timer counter 20

A timer block comprises a single channel 32-bit general purpose timer. This timer has an independent 32-bit counter and a dedicated prescaler that feeds counting clock. It supports periodic timer, PWM pulse, one-shot timer and capture mode.

One more optional free-run timer is provided. Main purpose of this timer is a periodical tick timer or a wake-up source. The Timer counter 20 features the followings:

- 32-bit up-counter and 12-bit prescaler
- Periodic timer, One-shot timer, PWM pulse, and Capture mode
- Synchronous start and clear function

8.2.1 Timer counter 20 block diagram

Figure 26 shows the block diagram of a timer block unit.

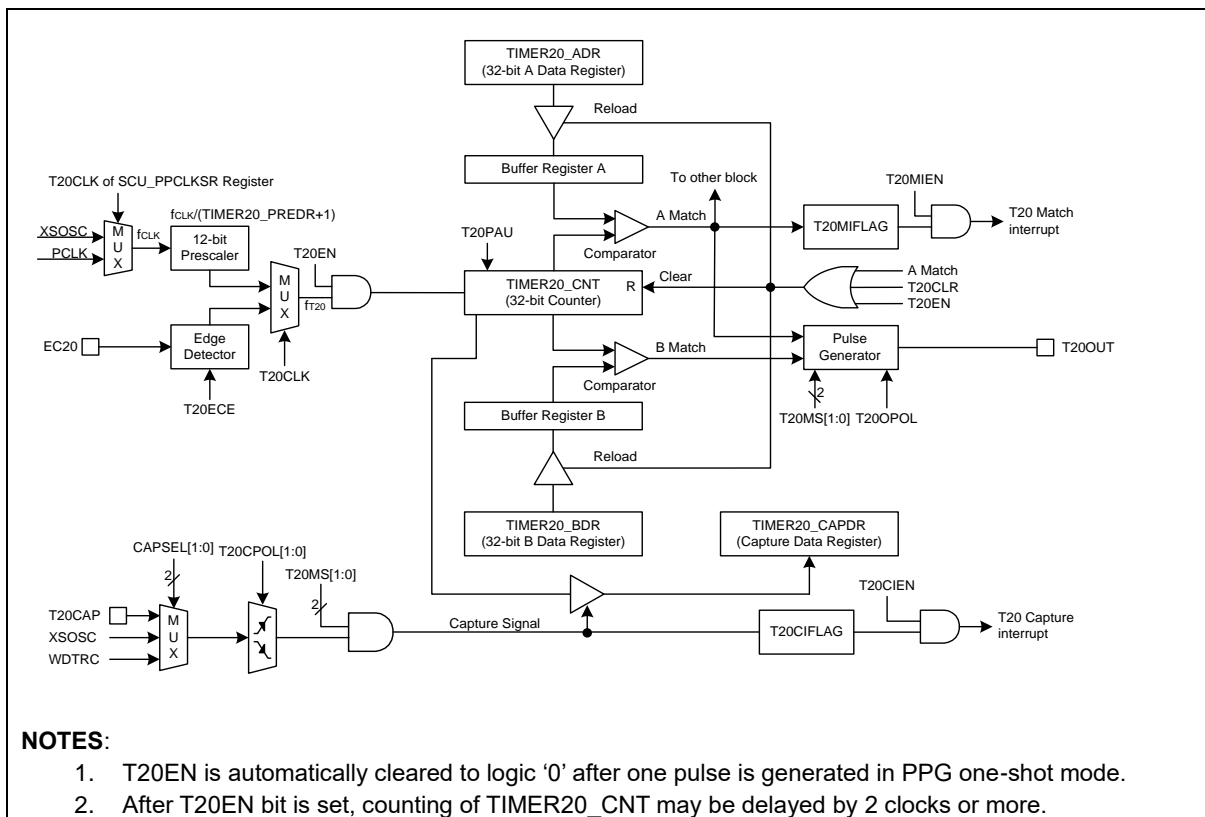

Figure 26. Timer Counter 20 Block Diagram

8.2.2 Pin description for Timer counter 20**Table 13. Pins and External Signals for Timer Counter 20**

PIN NAME	TYPE	DESCRIPTION
EC20	I	External clock input
T20CAP	I	Capture input
T20OUT	O	PWM/one-shot output

8.3 Timer counter 21

A timer block comprises a single channel 32-bit general purpose timer. This timer has an independent 32-bit counter and a dedicated prescaler that feeds counting clock. It supports periodic timer, PWM pulse, one-shot timer and capture mode.

One more optional free-run timer is provided. Main purpose of this timer is a periodical tick timer or a wake-up source. The Timer counter 21 features the followings:

- 32-bit up-counter and 12-bit prescaler
- Periodic timer, One-shot timer, PWM pulse, and Capture mode
- Synchronous start and clear function

8.3.1 Timer counter 21 block diagram

Figure 27 shows the block diagram of a timer block unit.

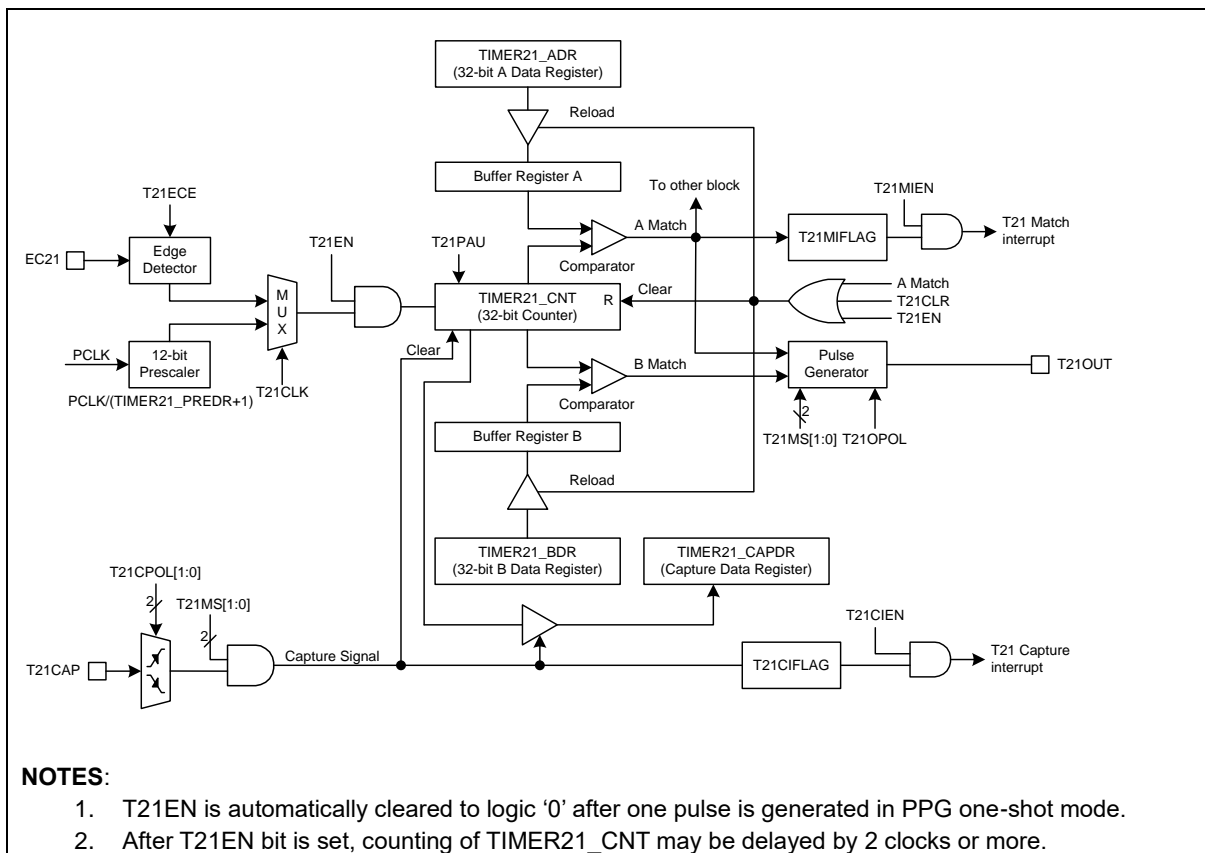

Figure 27. Timer Counter 21 Block Diagram

8.3.2 Pin description for Timer counter 21**Table 14. Pins and External Signals for Timer Counter 21**

PIN NAME	TYPE	DESCRIPTION
EC21	I	External clock input
T21CAP	I	Capture input
T21OUT	O	PWM/one-shot output

8.4 Timer counter 30

A timer counter 30 is a 16-bit timer with 3-phase PWM function. It has ADC triggering feature for motor control.

The Timer counter 30 features the followings:

- 16-bit up/down-counter and 12-bit prescaler
- Periodic timer, Back-to-Back timer, and Capture mode

8.4.1 Timer counter 30 block diagram

Figure 28 shows the block diagram of a timer block unit.

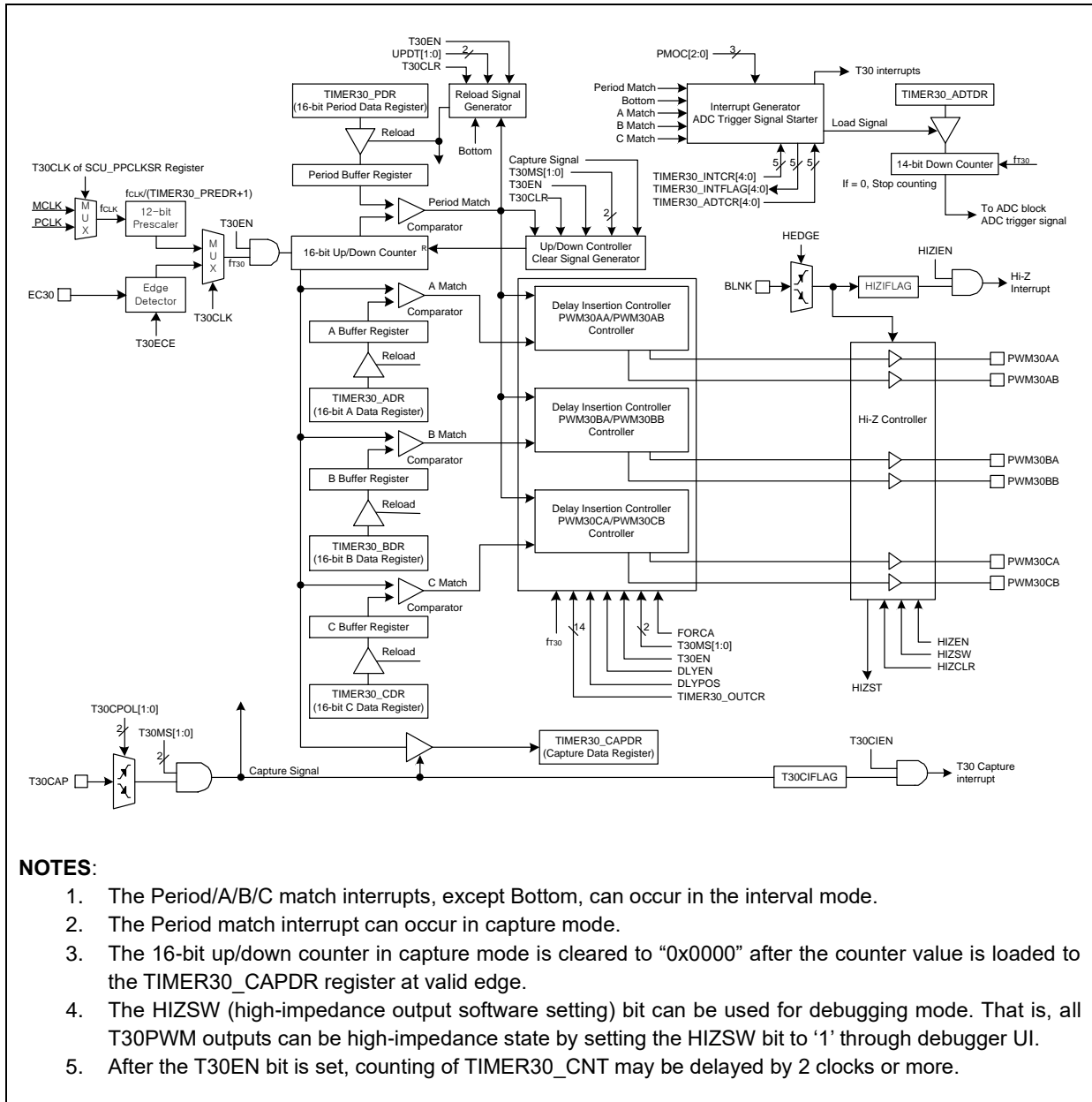

Figure 28. Timer Counter 30 Block Diagram

8.4.2 Pin description for Timer counter 30**Table 15. Pins and External Signals for Timer Counter 30**

PIN NAME	TYPE	DESCRIPTION
EC30	I	External clock input
T30CAP	I	Capture input
PWM30AA	O	PWM output
PWM30AB	O	PWM output
PWM30BA	O	PWM output
PWM30BB	O	PWM output
PWM30CA	O	PWM output
PWM30CB	O	PWM output

9 12-bit A/D Converter

ADC (Analog-to-Digital Converter) of A31G12x series allows conversion of an analog input signal to a corresponding 12-bit digital value. Its A/D module has fourteen analog inputs as shown in Figure 29. Output of the multiplexer is the input into the converter, which generates the result through successive approximation.

The A/D module has three registers such as a control register (ADC_CR), a data register (ADC_DR), and a prescaler data register (ADC_PREDR). The channels to be converted are selected by setting ADSEL[3:0]. The register ADC_DR contains the results of the A/D conversion. When the conversion is completed, the result is loaded into the ADC_DR, A/D conversion status bit ADCIFLAG is set to '1', and the A/D interrupt is set. During A/D conversion, ADCIFLAG bit is read as '0'. Main features of the ADC are listed in the followings:

- 14-channel of analog inputs
- S/W (ADST), Timer trigger (T10/11/12 A match, ADC trigger signal from T30) support
- Conversion time: 58 clocks
- 5-bit Prescaler

9.1 12-bit ADC block diagram

Figure 29 shows a block diagram of an ADC block.

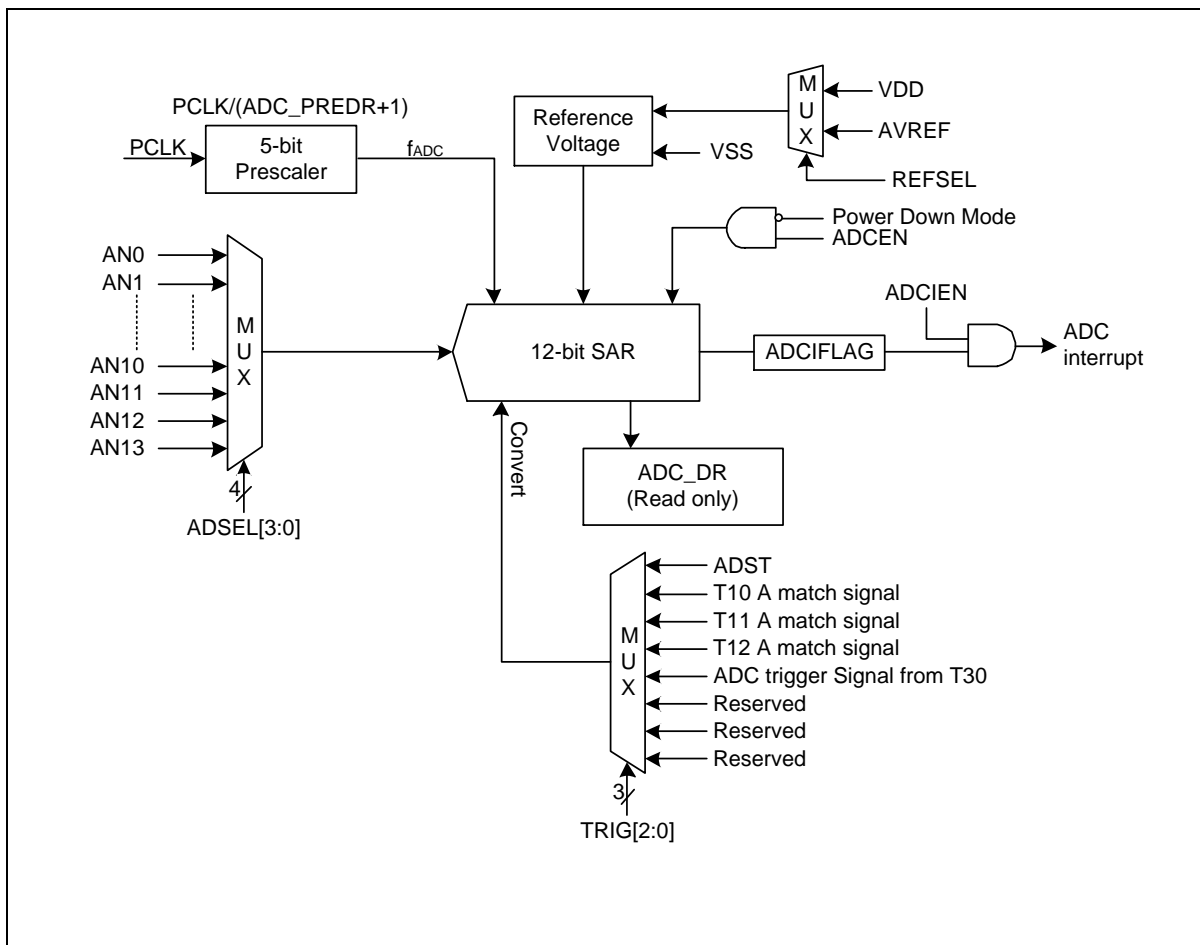

Figure 29. 12-bit ADC Block Diagram

9.2 Pin description for 12-bit ADC

Table 16. Pins and External Signals for 12-bit ADC

PIN NAME	TYPE	DESCRIPTION
VDD	P	Analog/Digital Power
VSS	P	Analog/Digital GND
AVREF	P	Analog Reference Voltage
AN0	A	ADC Input 0
AN1	A	ADC Input 1
AN2	A	ADC Input 2
AN3	A	ADC Input 3
AN4	A	ADC Input 4
AN5	A	ADC Input 5
AN6	A	ADC Input 6
AN7	A	ADC Input 7
AN8	A	ADC Input 8
AN9	A	ADC Input 9
AN10	A	ADC Input 10
AN11	A	ADC Input 11
AN12	A	ADC Input 12
AN13	A	ADC Input 13

NOTE: Where A=Analog, P= Power

10 USART 10/11/12/13 and UART 0/1

10.1 USART 10/11/12/13

USART (Universal Synchronous and Asynchronous serial Receiver and Transmitter) is a highly flexible serial communication device. The USART of A31G12x series features the followings:

- Full Duplex Operation. (Independent Serial Receive and Transmit Registers)
- Asynchronous or Synchronous Operation
- Baud Rate Generator
- Supports Serial Frames with 5,6,7,8, or 9 Data bits and 1 or 2 Stop bits
- Odd or Even Parity Generation, and Parity Check Supported by Hardware.
- Data OverRun Detection
- Framing Error Detection
- Three Separate Interrupts on TX Completion, TX Data Register Empty and RX Completion
- Double Speed Asynchronous communication mode

10.1.1 USART 10/11/12/13 block diagram

Figure 30 shows a block diagram of the UART block.

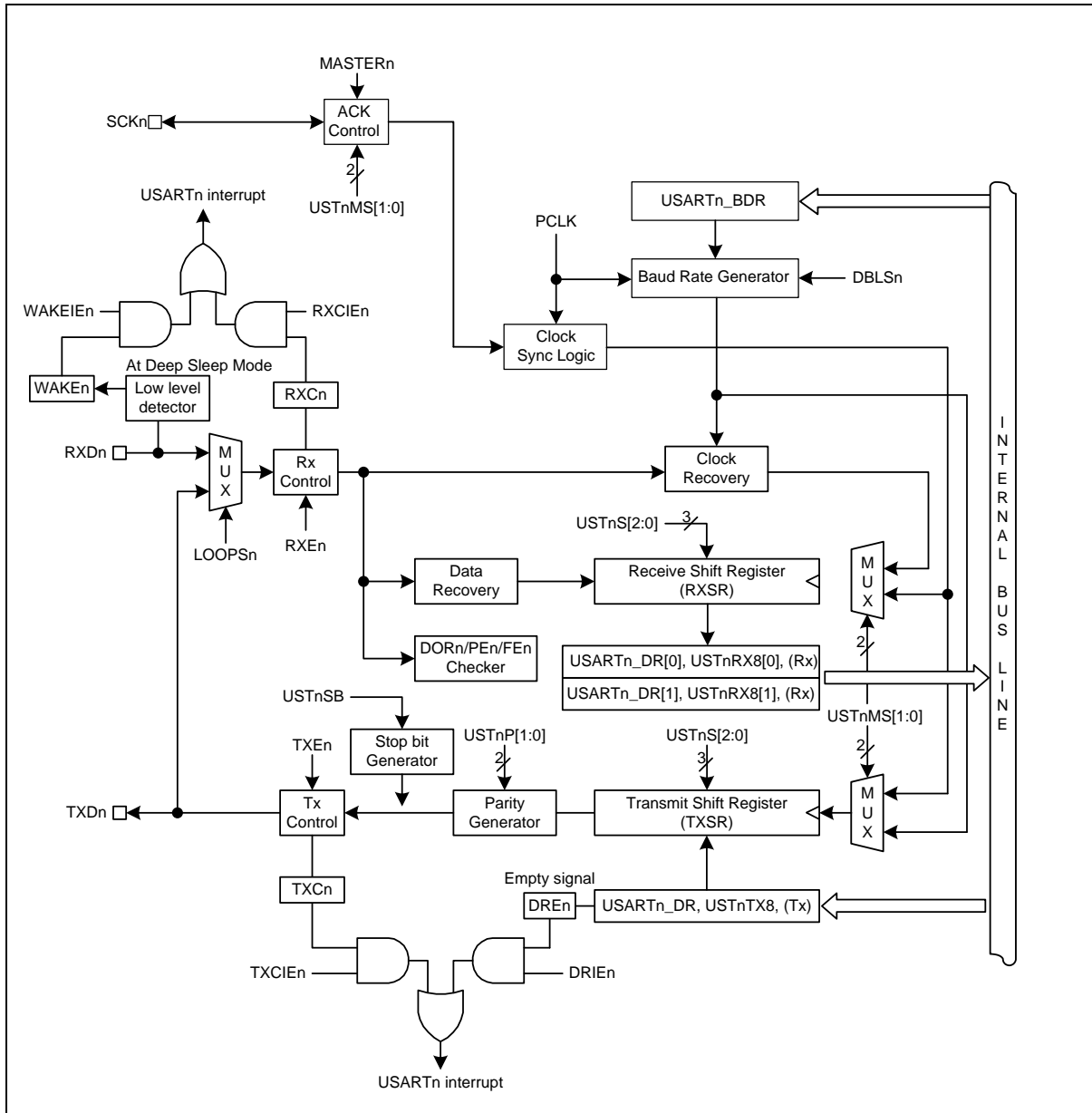

Figure 30. USART n Block Diagram of USART (n = 10, 11, 12 and 13)

10.2 UART 0/1

There are built-in 2-channel of UART module (Universal Asynchronous Receiver/Transmitter) in A31G12x series. UART operation status including error status can be read from a status register.

A prescaler, which generates proper baud rate, exists for each UART channel. The prescaler can divide the UART clock source, PCLK, from 3 to 65535. Then, baud rate is generated using a 1:16 clock and an 8-bit precision clock tuning function.

The UART 0/1 of A31G12x series features the followings:

- Compatible with 16450
- Configurable standard asynchronous control bit (start, stop, and parity)
- Programmable 16-bit fractional baud generator
- Programmable serial communication
- 5-, 6-, 7- or 8- bit data transfer
- Even, odd, or no-parity bit insertion and detection
- 1-, 1.5- or 2-stop bit-insertion and detection
- 16-bit baud rate generation with 8-bit fraction control
- Hardware inter-frame delay function
- Stop bit error detection
- Detail status register

10.2.1 UART 0/1 block diagram

Figure 32 shows a block diagram of the UART block.

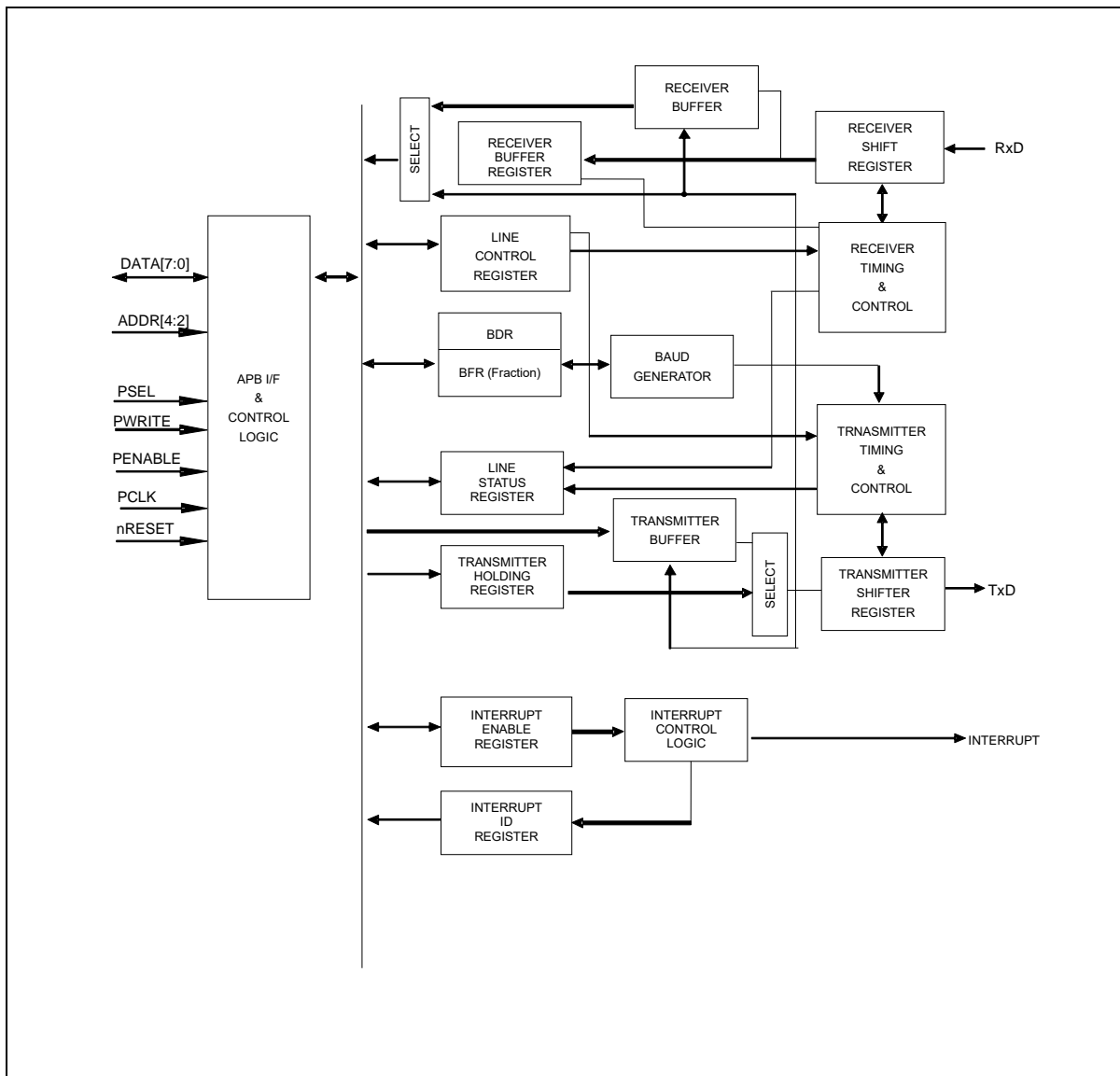

Figure 32. UART 0/1 Block Diagram

10.2.2 Pin description for UART 0/1

Table 18. Pins and External Signals for UART 0/1

PIN NAME	TYPE	DESCRIPTION
TXD0	O	UART Channel 0 transmit output
RXD0	I	UART Channel 0 receive input
TXD1	O	UART Channel 1 transmit output
RXD1	I	UART Channel 1 receive input

11 I2C 0/1/2 interface

I2C is one of industrial standard serial communication protocols, which uses 2 bus lines, Serial Data Line (SDAn) and a Serial Clock Line (SCLn), to exchange data. Because both SDAn and SCLn lines are open-drain output, each line needs a pull-up resistor (n = 0, 1 and 2).

The I2C 0/1/2 of A31G12x series features the followings:

- Compatible with I2C bus standard
- Multi-master operation
- Up to 1MHz data transfer read speed
- 7-bit address
- Support two slave addresses
- Both master and slave operation
- Bus busy detection

12 LCD driver

LCD driver of A31G12x series includes an LCD control register (LCD_CR) and an LCD driver bias and contrast control register (LCD_BCCR). LCLK[1:0] of the LCD_CR determines frequency of COM signal scanning each segment output. A RESET clears the LCD_CR and sets the LCD_BCCR to logic '0'.

LCD display can continue its operation even during Sleep mode and Deep sleep mode if it uses a selected clock for LCD driver.

A clock and duty of the LCD driver is initialized by hardware whenever a value is written to the control register. So, it is recommended not to rewrite the LCD_CR frequently.

12.1 LCD driver block diagram

Figure 34 shows a block diagram of the LCD driver block.

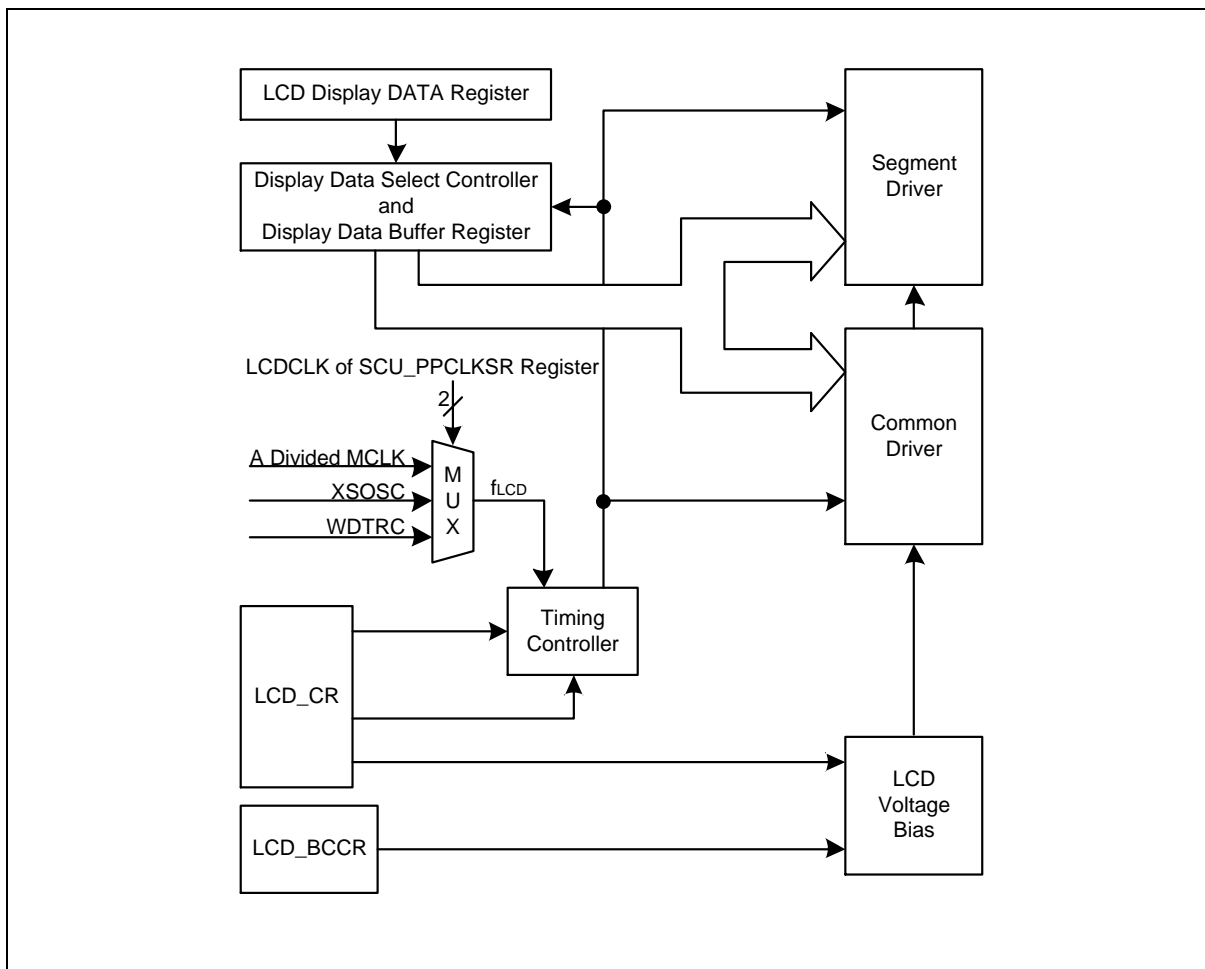

Figure 34. LCD Driver Block Diagram

12.2 Pin description for LCD driver

Table 20. Pins and External Signals for LCD Driver

PIN NAME	TYPE	DESCRIPTION
COM0 to COM7	O	LCD common signal outputs
SEG0 to SEG43	O	LCD segment signal outputs

13 CRC and checksum

A CRC (cyclic redundancy check) generator is used to obtain 16-bit CRC code of Flash ROM and any data stream.

Among other applications, CRC-based techniques are used to verify data transmission or storage integrity. In the scope of functional safety standards, they offer means of verifying Flash memory's integrity.

The CRC generator helps computing the signature of the software during runtime, comparing with a reference signature.

A CRC generator of A31G12x series has following features:

- Auto CRC and User CRC Mode
- Supports CRC-CCITT ($G_1(x) = x^{16} + x^{12} + x^5 + 1$)
- Supports CRC-16 ($G_2(x) = x^{16} + x^{15} + x^2 + 1$)
- CRC and Checksum mode
- CRC/Checksum Start Address Auto Increment (User mode only)

13.1 CRC and checksum block diagram

Figure 35 shows a block diagram of the CRC and checksum interface block.

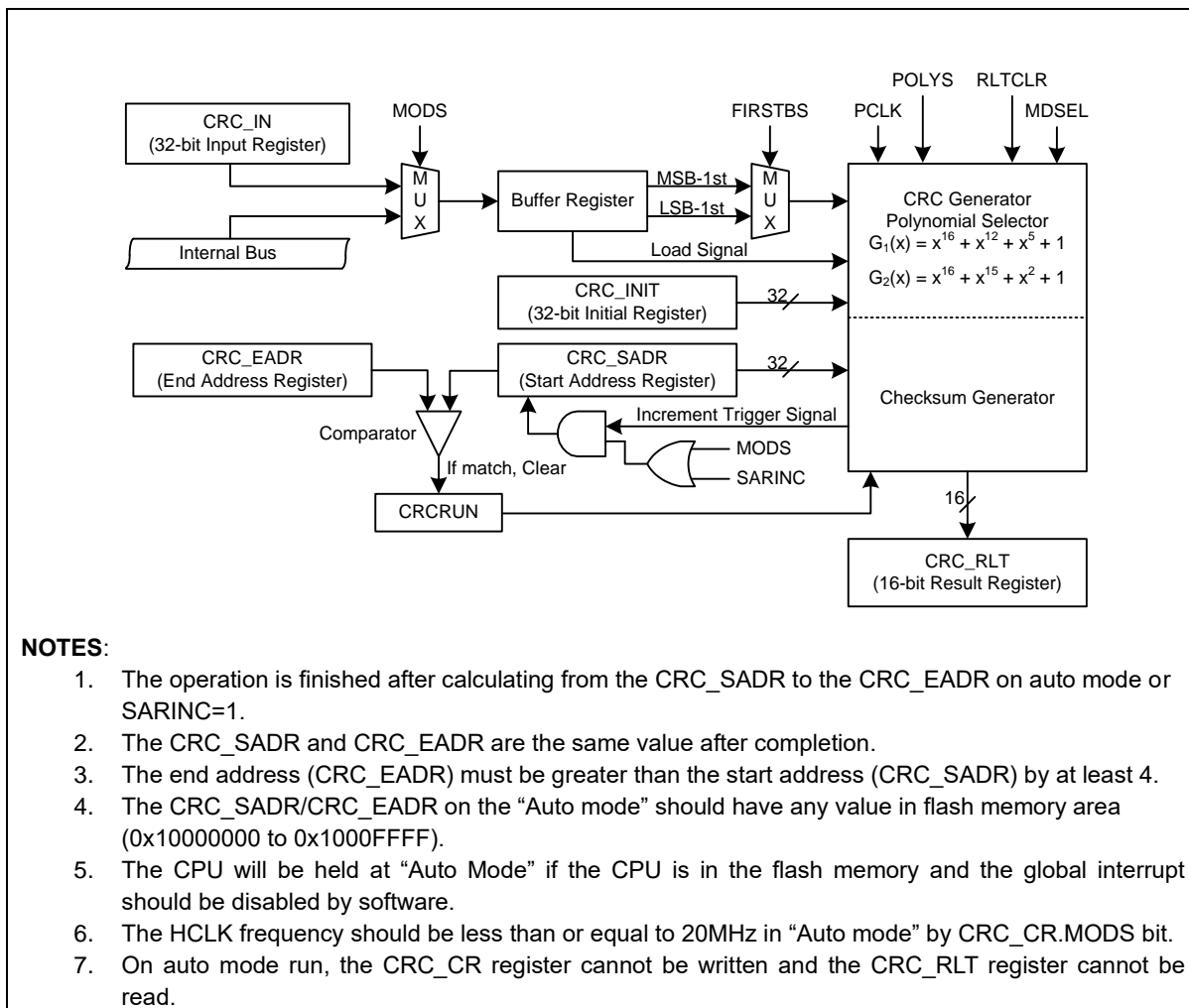

Figure 35. CRC and Checksum Block Diagram

14 Electrical characteristics

Unless otherwise specified, test conditions for DC characteristics are as shown in the followings:

- $T_A = -40\text{ }^{\circ}\text{C}$ to $+85\text{ }^{\circ}\text{C}$ (Commercial grade) or $T_A = -40\text{ }^{\circ}\text{C}$ to $+105\text{ }^{\circ}\text{C}$ (Industrial grade)
- $V_{DD} = 1.8$ to 5.5V

NOTE: Refer to Figure 57. A31G12x series Numbering Nomenclature for device part number by Commercial grade.

14.1 Absolute maximum ratings

Absolute maximum ratings are limiting values of operating and environmental conditions, which should not be exceeded under the worst possible conditions.

Table 21. Absolute Maximum Ratings

Parameter	Symbol	Ratings	Unit	Note
Supply voltage	V _{DD}	-0.3 to +6.5	V	–
Normal pin	V _I	-0.3 to V _{DD} +0.3	V	Voltage on any pin with respect to VSS
	V _O	-0.3 to V _{DD} +0.3	V	
	I _{OH}	-18	mA	Maximum current output sourced by (I _{OH} per I/O pin)
	ΣI _{OH}	-150	mA	Maximum current (ΣI _{OH})
	I _{OL}	140	mA	Maximum current sunk by (I _{OL} per I/O pin)
	ΣI _{OL}	170	mA	Maximum current (ΣI _{OL})
Total power dissipation	P _T	850	mW	–
Storage temperature	T _{STG}	-65 to +150	°C	–

14.2 Recommended operating conditions

Table 22. Recommended Operating Conditions

Parameter	Symbol	Conditions	Min	Max	Units		
Operating voltage	VDD	fx = 32 to 38kHz	Sub Clock		V		
		fx = 2.0 to 4.2MHz	Main Clock	Ceramic		2.2	5.5
		fx = 2.0 to 16MHz		Crystal		2.7	5.5
		fx = 2.0 to 40MHz	External Clock			3.0	5.5
		fx = 40kHz	Internal RC			1.8	5.5
		fx = 2.5 to 40MHz				1.8	5.5
Operating temperature	T _{OPR}	VDD = 1.8 to 5.5V (Commercial grade)	-40	85	°C		
		VDD = 1.8 to 5.5V (Industrial grade)	-40	105			

14.3 ADC characteristics

Table 23. ADC Characteristics

(VDD = 2.2V to 5.5V)

Parameter	Symbol	Conditions	Min	Typ	Max	Units	
Resolution	–	–	–	12	–	bit	
Integral non-linearity	INL	AVREF=2.7V – 5.5V, T _A = 25 °C	–	–	±5	LSB	
Differential non-linearity	DNL		–	–	±1		
Zero offset error	ZOE		–	–	±4		
Full scale error	FSE		–	–	±8		
Conversion time	t _{CONV}	AVREF=4.0V – 5.5V	20	–	–	μs	
		AVREF=3.0V – 5.5V	30	–	–		
		AVREF=2.7V – 5.5V	60	–	–		
Analog input voltage	V _{AN}	–	VSS	–	AVREF	V	
Analog reference voltage	AVREF	–	2.2	–	VDD	V	
ADC input leakage current	I _{AN}	AVREF=5.0V	–	–	2	μA	
ADC current	I _{ADC}	Enable	VDD=5.0V	–	1	2	mA
		Disable		–	–	0.1	μA

NOTES:

1. Zero offset error is a difference between 0x000 and the converted output for zero input voltage (VSS).
2. Full scale error is a difference between 0xFFFF and the converted output for top input voltage (VDD).
3. If AVREF is less than 2.7V, the resolution degrades by 1-bit whenever AVREF drops 0.1V.
(It is recommended that the clock of ADC is 0.5MHz under 2.7V)

14.4 Power-on reset characteristics

Table 24. Power-on Reset Characteristics

Parameter	Symbol	Conditions	Min	Typ	Max	Units
Reset release level	V_{POR}	–	–	1.2	–	V
Hysteresis	ΔV	–	–	0.2	–	V
VDD voltage rising time	t_R	0.2V to 2.0V	0.05	–	100	V/ms
POR current	I_{POR}	–	–	0.1	–	μA

14.5 Low voltage reset characteristics

Table 25. Low Voltage Reset Characteristics

Parameter	Symbol	Conditions	Min	Typ	Max	Units	
Detection level	V _{LVR}	Falling edge voltage	–	1.62	1.77	V	
			1.85	2.00	2.15		
			1.98	2.13	2.28		
			2.13	2.28	2.43		
			2.31	2.46	2.61		
			2.47	2.67	2.87		
			2.84	3.04	3.24		
			3.00	3.20	3.40		
			3.35	3.55	3.75		
			3.45	3.75	4.05		
			3.69	3.99	4.29		
			3.95	4.25	4.55		
			4.25	4.55	4.85		
Hysteresis	ΔV	–	–	100	200	mV	
Minimum pulse width	t _{LW}	–	100	–	–	μ s	
LVR current	I _{LVR}	Enable, All mode	VDD = 5V	–	10.0	20.0	μ A
		Disable		–	–	0.1	

14.6 Low voltage indicator characteristics

Table 26. Low Voltage Indicator Characteristics

Parameter	Symbol	Conditions		Min	Typ	Max	Units
Detection level	V_{LVI}	Falling edge voltage		1.85	2.00	2.15	V
				1.98	2.13	2.28	
				2.13	2.28	2.43	
				2.31	2.46	2.61	
				2.47	2.67	2.87	
				2.84	3.04	3.24	
				3.00	3.20	3.40	
				3.35	3.55	3.75	
				3.45	3.75	4.05	
				3.69	3.99	4.29	
			3.95	4.25	4.55		
			4.25	4.55	4.85		
Hysteresis	ΔV	–		–	–	200	mV
Minimum pulse width	t_{LW}	–		100	–	–	μs
LVI current	I_{LVI}	Enable, All mode	VDD = 5V	–	10.0	20.0	μA
		Disable		–	–	0.1	

14.7 High frequency internal RC oscillator characteristics

Table 27. High Frequency Internal RC Oscillator Characteristics

Parameter	Symbol	Conditions	Min	Typ	Max	Units
Frequency	f_{HIRC}	VDD = 1.8V to 5.5V	–	40	–	MHz
Accuracy	–	$T_A = 0\text{ }^{\circ}\text{C to }+50\text{ }^{\circ}\text{C}$	–	–	± 1.5	%
		$T_A = -40\text{ }^{\circ}\text{C to }+85\text{ }^{\circ}\text{C(Commercial grade)}$	–	–	± 3.5	
		$T_A = -40\text{ }^{\circ}\text{C to }+105\text{ }^{\circ}\text{C(Industrial grade)}$	–	–	± 4.5	
Clock duty ratio	T_{OD}	–	40	50	60	%
Stabilization time	t_{HFS}	–	–	–	100	μs
IRC current	I_{HIRC}	Enable	–	500	–	μA
		Disable	–	–	0.1	μA

14.8 Internal watchdog timer RC oscillator characteristics

Table 28. Internal Watchdog Timer RC Oscillator Characteristics

Parameter	Symbol	Conditions	Min	Typ	Max	Units
Frequency	f_{WDTRC}	–	36	40	44	kHz
Stabilization time	t_{WDTS}	–	–	–	1	ms
WDTRC current	I_{WDTRC}	Enable	–	3	6	μA
		Disable	–	–	0.1	

14.9 LCD voltage characteristics

Table 29. LCD Voltage Characteristics

Parameter	Symbol	Conditions	Min	Typ	Max	Units	
LCD voltage	VLC0	LCD contrast disabled, 1/4 bias	Typx0.95	VDD	Typx1.05	V	
		LCD contrast enabled, 1/4 bias, No Panel load	VLCD[3:0]=0x00	Typx0.94	VDD x16/31	Typx1.06	V
			VLCD[3:0]=0x01		VDD x16/30		
			VLCD[3:0]=0x02		VDD x16/29		
			VLCD[3:0]=0x03		VDD x16/28		
			VLCD[3:0]=0x04		VDD x16/27		
			VLCD[3:0]=0x05		VDD x16/26		
			VLCD[3:0]=0x06		VDD x16/25		
			VLCD[3:0]=0x07		VDD x16/24		
			VLCD[3:0]=0x08		VDD x16/23		
			VLCD[3:0]=0x09		VDD x16/22		
			VLCD[3:0]=0x0A		VDD x16/21		
			VLCD[3:0]=0x0B		VDD x16/20		
			VLCD[3:0]=0x0C		VDD x16/19		
			VLCD[3:0]=0x0D		VDD x16/18		
VLCD[3:0]=0x0E	VDD x16/17						
VLCD[3:0]=0x0F	VDD x16/16						
LCD mid bias voltage ^(NOTE)	VLC1	VDD = 2.7V to 5.5V, LCD clock = 0Hz, 1/4 bias, No panel load	Typ-0.2	3/4xVLC0	Typ+0.2	V	
	VLC2		Typ-0.2	2/4xVLC0	Typ+0.2		
	VLC3		Typ-0.2	1/4xVLC0	Typ+0.2		
LCD driver output impedance	R _{LO}	VLCD=3V	–	5	10	kΩ	
LCD bias dividing resistor	RLCD1	1/4 bias, TA=25°C	7.0	10	13.0	kΩ	
	RLCD2		35	50	65		
	RLCD3		56	80	104		
	RLCD4		168	240	312		

NOTE: It is the middle output voltage when the VDD and the VLC0 node are connected.

14.10 DC electrical characteristics

Table 30. DC Electrical Characteristics

Parameter	Symbol	Conditions	Min	Typ	Max	Units	
Input High Voltage	V_{IH}	All input pins, nRESET	0.8VDD	–	VDD	V	
Input Low Voltage	V_{IL}	All input pins, nRESET	–	–	0.2VDD	V	
Input hysteresis	ΔV	All input pins, nRESET, VDD=3V	100	200	–	mV	
Output High Voltage	V_{OH1}	VDD=4.5V, $I_{OH1} = -2\text{mA}$, All output pins except V_{OH2}	VDD-1.0	–	–	V	
	V_{OH2}	VDD=4.5V, $T_A=25^\circ\text{C}$, $I_{OH2} = -15\text{mA}$, PE0-PE7	VDD-2.0	–	–		
Output Low Voltage	V_{OL1}	VDD=4.5V, $I_{OL1} = 10\text{mA}$, All output pins except V_{OL2}	–	–	1.0	V	
	V_{OL2}	VDD=4.5V, $I_{OL2} = 120\text{mA}$, PD0-PD7	–	1.5	3.0		
Input high leakage current	I_{IH}	All Input ports	–	–	1	μA	
Input low leakage current	I_{IL}	All Input ports	– 1	–	–	μA	
Pull-up resistor	R_{PU}	$V_I=0\text{V}$, $T_A=25^\circ\text{C}$, All Input ports	VDD=5V	25	50	100	k Ω
			VDD=3V	50	100	200	
		$V_I=0\text{V}$, $T_A=25^\circ\text{C}$, RESETB	VDD=5V	150	250	400	
			VDD=3V	300	500	700	
Pull-down resistor	R_{PD}	$V_I=VDD$, $T_A=25^\circ\text{C}$, All Input ports	VDD=5V	13	25	50	k Ω
			VDD=3V	25	50	100	
OSC feedback resistor	R_{X1}	XIN=VDD, XOUT=VSS, $T_A=25^\circ\text{C}$, VDD=5V	600	1,200	2,000	k Ω	
	R_{X2}	SXIN=VDD, SXOUT=VSS, $T_A=25^\circ\text{C}$, VDD=5V	2.5	5	10	M Ω	

14.11 Supply current characteristics

Table 31. Supply Current Characteristics

Parameter	Symbol	Conditions	Typ	Max	Units	
Supply current	IDD1 (run)	f _{HIRC} = 40MHz	VDD=5V±10%	6.5	13.0	mA
		f _{HIRC} = 20MHz	VDD=5V±10%	4.0	8.0	
		f _{XIN} = 16MHz	VDD=5V±10%	5.0	10.0	
			VDD=3V±10%	3.5	7.0	
	IDD2 (sleep)	f _{HIRC} = 40MHz	VDD=5V±10%	4.0	8.0	mA
		f _{HIRC} = 20MHz	VDD=5V±10%	2.5	5.0	
		f _{XIN} = 16MHz	VDD=5V±10%	3.2	6.4	
			VDD=3V±10%	2.0	4.0	
	IDD3	f _{SUB} = 32.768kHz or	Sub run	90	180	uA
	IDD4	f _{WDTRC} = 40kHz, VDD=3V±10%, TA=25°C	Sub sleep	7.5	15.0	
IDD5		Deep sleep, VDD=5V±10%, TA=25°C	0.5	3.0		

NOTES:

1. f_{XIN} is an external main oscillator, f_{SUB} is an external sub oscillator, f_{HIRC} is a high frequency internal RC oscillator, and fx is the selected system clock.
2. All supply current items don't include the current of an internal watch-dog timer RC (WDTRC) oscillator and peripheral blocks.
3. All supply current items include the current of the power-on reset (POR) block.

14.12 AC characteristics

Table 32. AC Characteristics

Parameter	Symbol	Conditions	Min	Typ	Max	Units
RESETB input low width	t_{RST}	VDD = 5 V	10	–	–	μs
Interrupt input high, low width	t_{IWH}, t_{IWL}	All interrupts, VDD = 5 V	100	–	–	ns
External counter input high, low pulse width	t_{ECWH}, t_{ECWL}	VDD = 5 V All external counter input	100	–	–	
External counter transition time	t_{REC}, t_{FEC}	ECn, VDD = 5 V All external counter input	–	–	20	

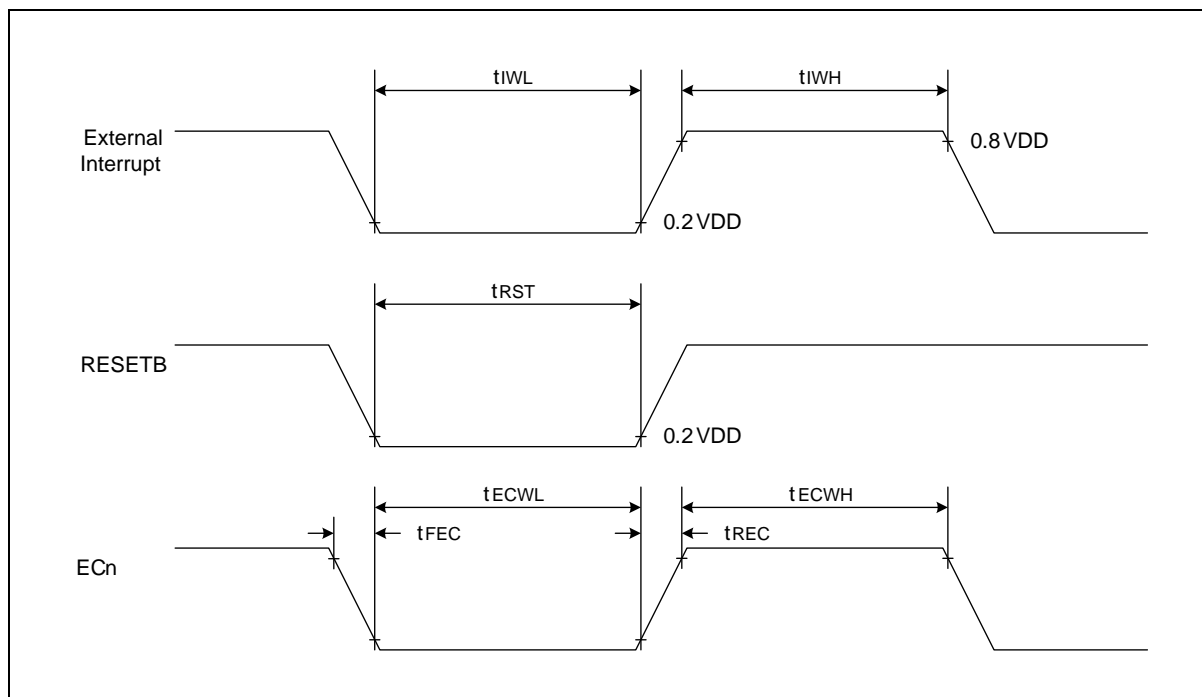

Figure 36. AC Timing

14.13 SPI characteristics

Table 33. SPI Characteristics

(VDD = 2.7V to 5.5V)

Parameter	Symbol	Conditions	Min	Typ	Max	Units
Output Clock Pulse Period	t_{SCK}	Internal SCK source	400	–	–	ns
Input Clock Pulse Period		External SCK source	400	–	–	
Output clock high, low pulse width	t_{SCKH} , t_{SCKL}	Internal SCK source	180	–	–	
Input clock high, low pulse width		External SCK source	180	–	–	
First output clock delay time	t_{FOD}	Internal/External SCK source	200	–	–	
Output clock delay time	t_{DS}	–	–	–	100	
Input setup time	t_{DIS}	–	180	–	–	
Input hold time	t_{DIH}	–	180	–	–	

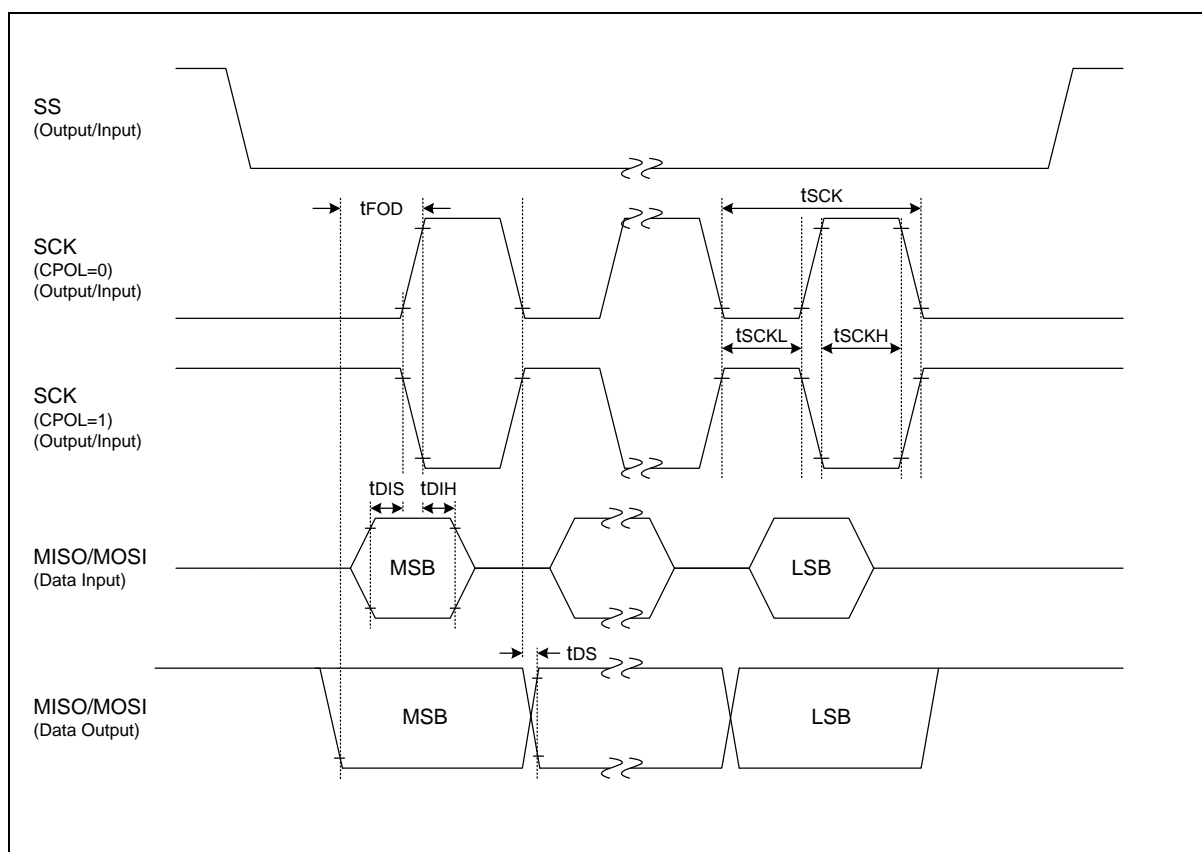

Figure 37. SPI Timing

14.14 I2C characteristics

Table 34. I2C Characteristics

Parameter	Symbol	Standard		Fast		Fast Plus		Units
		Min	Max	Min	Max	Min	Max	
I2C operating voltage	–	VDD ≥ 1.8V		VDD ≥ 2.0V		VDD ≥ 2.7V		–
Clock frequency	t _{SCL}	0	100	0	400	0	1000	kHz
Clock high pulse width	t _{SCLH}	4.0	–	0.6	–	0.26	–	μs
Clock low pulse width	t _{SCLL}	4.7	–	1.3	–	0.5	–	
Bus free time	t _{BF}	4.7	–	1.3	–	0.5	–	
Start condition setup time	t _{STSU}	4.7	–	0.6	–	0.26	–	ns
Start condition hold time	t _{STHD}	4.0	–	0.6	–	0.26	–	
Stop condition setup time	t _{SPSU}	4.0	–	0.6	–	0.26	–	
Stop condition hold time	t _{SPHD}	4.0	–	0.6	–	0.26	–	
Output Valid from Clock	t _{VD}	0	–	0	–	0	–	
Data input hold time	t _{DIH}	0	–	0	1.0	0	0.45	
Data input setup time	t _{DIS}	250	–	100	–	50	–	

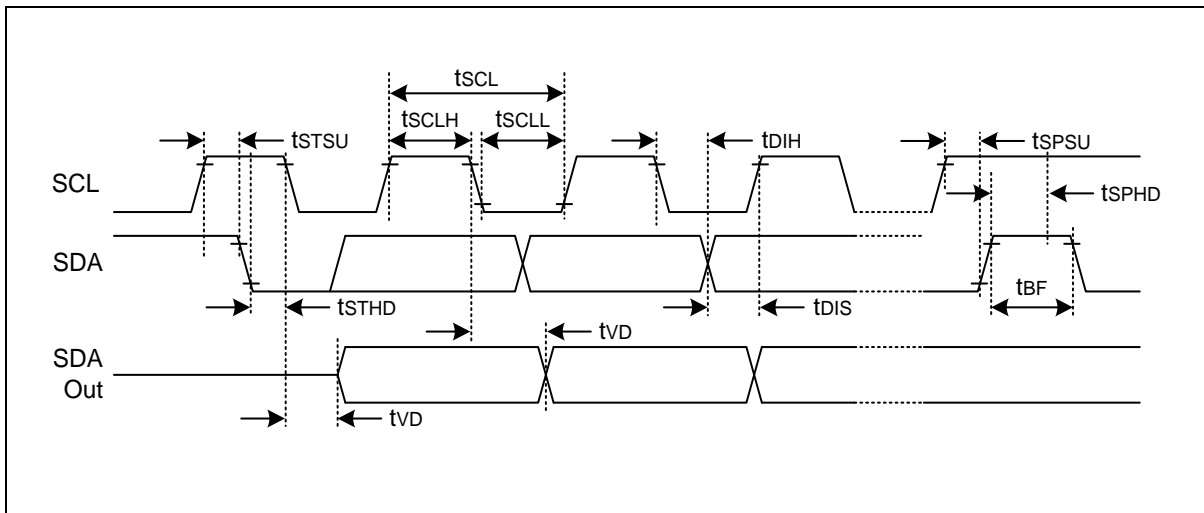

Figure 38. I2C Timing

14.15 UART timing characteristics

Table 35. UART Timing Characteristics (PCLK=11.1MHz)

Parameter	Symbol	Min	Typ	Max	Units
Serial port clock cycle time	t_{SCK}	1,250	$t_{CPU} \times 16$	1,650	ns
Output data setup to clock rising edge	t_{S1}	590	$t_{CPU} \times 13$	–	
Clock rising edge to input data valid	t_{S2}	–	–	590	
Output data hold after clock rising edge	t_{H1}	$t_{CPU} - 50$	t_{CPU}	–	
Input data hold after clock rising edge	t_{H2}	0	–	–	
Serial port clock High, Low level width	t_{HIGH} , t_{LOW}	470	$t_{CPU} \times 8$	970	

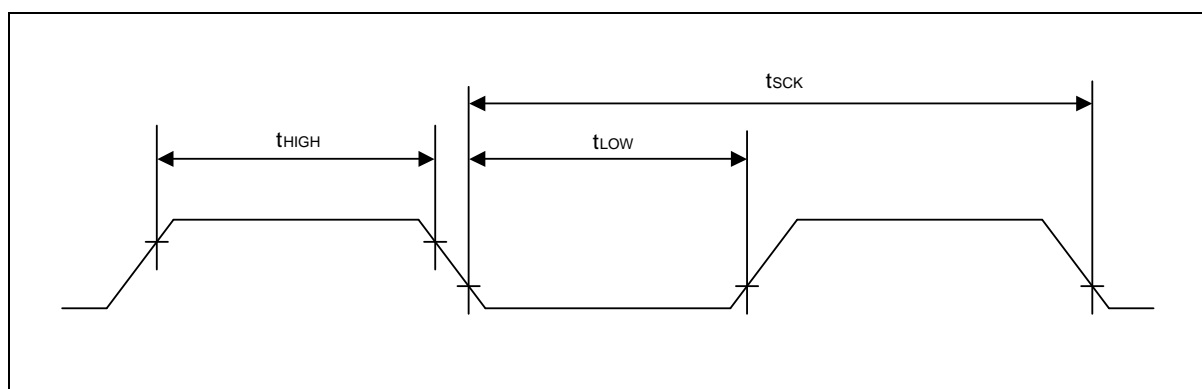

Figure 39. UART Timing Characteristics

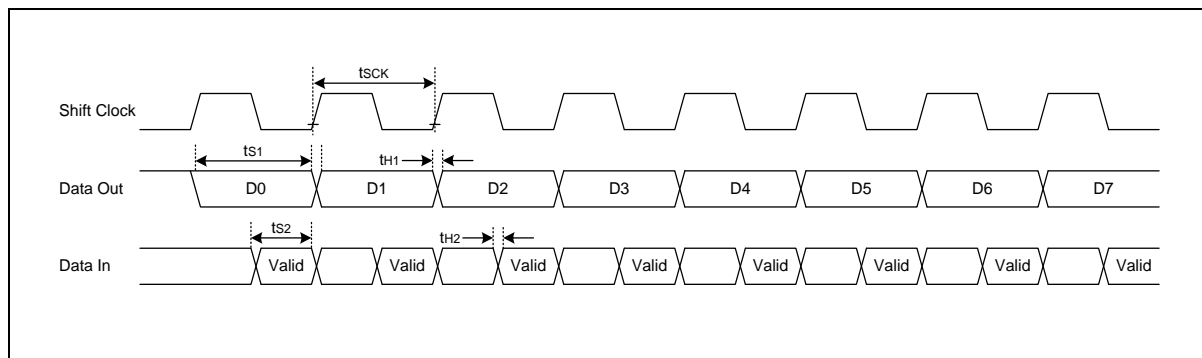

Figure 40. Timing Waveform of UART Module

14.16 Data retention voltage in Stop mode

Table 36. Data Retention Voltage in Stop Mode

Parameter	Symbol	Conditions	Min	Typ	Max	Units
Data retention supply voltage	V _{DDDR}	–	1.8	–	5.5	V
Data retention supply current	I _{DDDR}	<ul style="list-style-type: none">• V_{DDDR} = 1.8V (T_A=25°C)• Deep sleep mode	–	–	1	μA

14.17 Internal flash characteristics

Table 37. Internal Flash Characteristics

Parameter	Symbol	Conditions	Min	Typ	Max	Units	
Page write time	t_{FSW}	–	–	3.0	3.5	ms	
Page erase time	t_{FSE}	–	–	3.0	3.5		
Chip erase time	t_{FCE}	–	–	3.0	3.5		
Flash program voltage	V_{PGM}	On erase/write	2.0	–	5.5	V	
System clock frequency	f_{HCLK}	–	2.0	–	–	MHz	
Endurance of Write/Erase	NF _{WE}	<ul style="list-style-type: none"> • Page 0 to 511 • Configure Option Page 1 	T _A =25 °C, Page unit	10,000	–	–	Cycles
		Configure Option Page 2/3		100,000	–	–	
Retention time	t_{RT}		10	–	–	Years	

14.18 Input/output capacitance**Table 38. Input/Output Capacitance**

(VDD = 0V)

Parameter	Symbol	Conditions	Min	Typ	Max	Units
Input capacitance	C _{IN}	• f=1MHz • Unmeasured pins are connected VSS	–	–	10	pF
Output capacitance	C _{OUT}					
I/O capacitance	C _{IO}					

14.19 Main oscillator characteristics

Table 39. Main Oscillator Characteristics

(VDD = 2.2V to 5.5V)

Oscillator	Parameter	Conditions	Min	Typ	Max	Units
Crystal	Main oscillation frequency	2.7 V to 5.5 V	2.0	–	16.0	MHz
Ceramic Oscillator	Main oscillation frequency	2.2 V to 5.5 V	2.0	–	4.2	
		2.7 V to 5.5 V	2.0	–	16.0	
External Clock	XIN input frequency	3.0 V to 5.5 V	2.0	–	40.0	MHz
	External Clock Duty Ratio	–	–	50	–	%

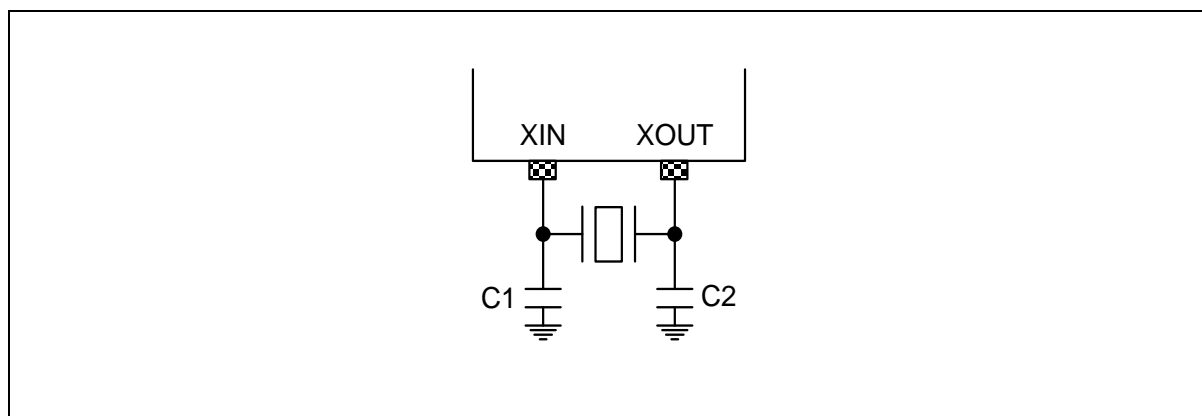

Figure 41. Crystal/Ceramic Oscillator

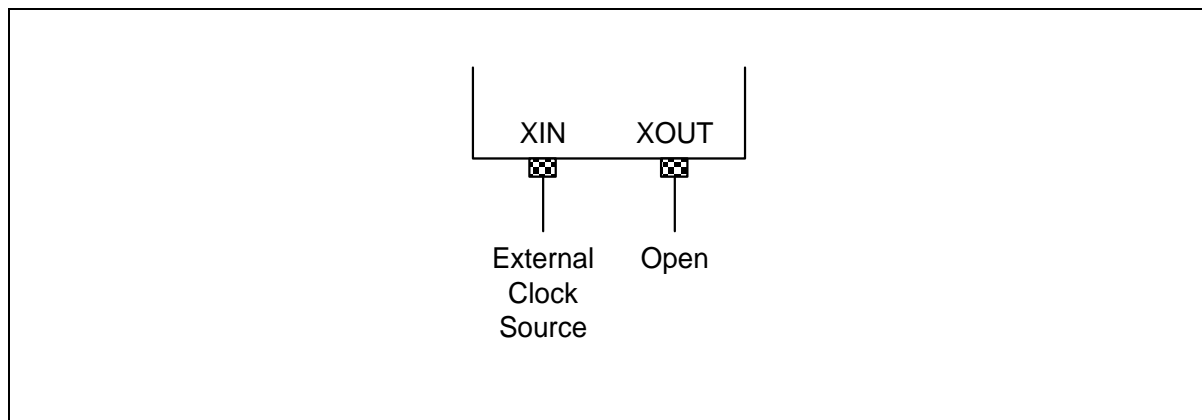

Figure 42. External Clock

14.20 Sub-oscillator characteristics

Table 40. Sub-oscillator Characteristics

Oscillator	Parameter	Conditions	Min	Typ	Max	Units
Crystal	Sub oscillation frequency	–	32	32.768	38	kHz
External Clock	SXIN input frequency		32	–	38	

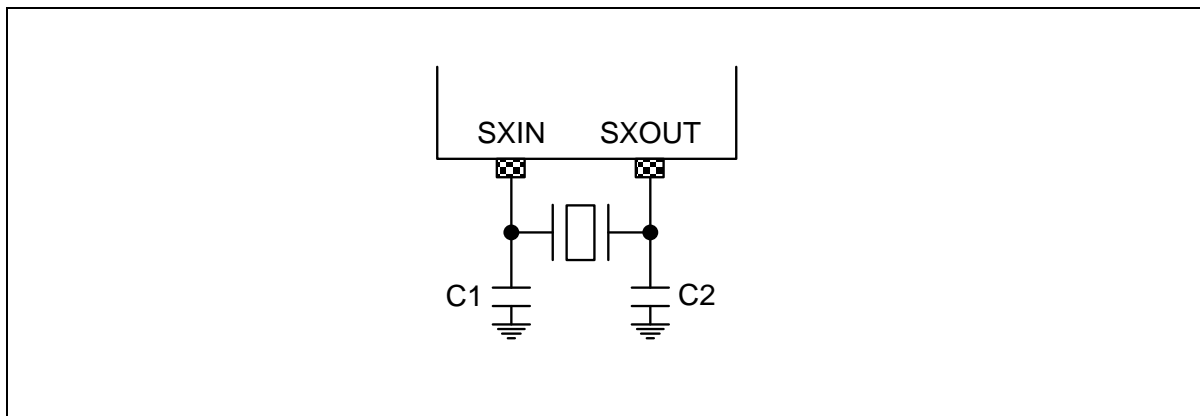

Figure 43. Crystal Oscillator

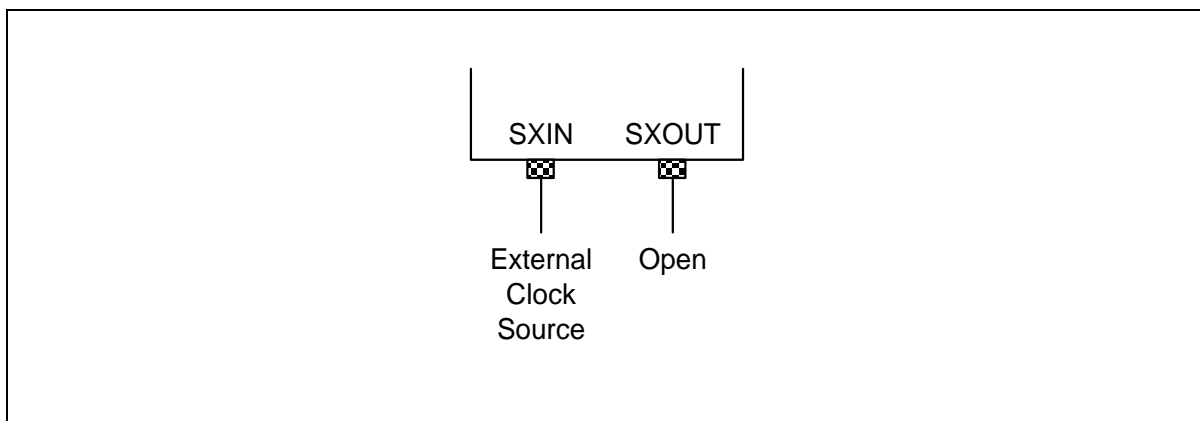

Figure 44. External Clock

14.21 Main oscillation stabilization time

Table 41. Main Oscillation Stabilization Time

Oscillator	Conditions	Min	Typ	Max	Unit	
Crystal	<ul style="list-style-type: none"> $f_{XIN} \geq 2\text{MHz}$ Oscillation stabilization occurs when VDD is equal to the minimum oscillator voltage range. 	VDD = 2.7V to 5.5V	–	–	60	ms
Ceramic		VDD = 2.2V to 5.5V	–	–	10	
External clock	<ul style="list-style-type: none"> $f_{XIN} = 2.0$ to 40MHz XIN input high and low width (t_{XL}, t_{XH}) 	12.5	–	250	ns	

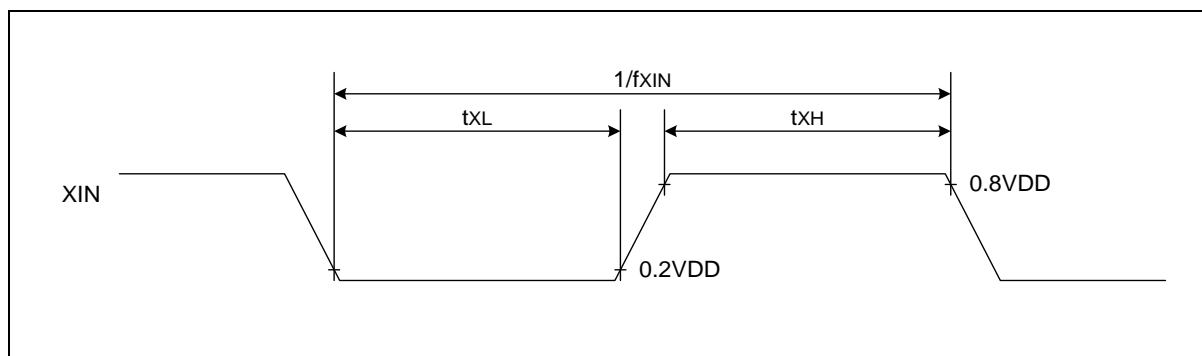

Figure 45. Clock Timing Measurement at XIN

14.22 Sub-oscillation stabilization time

Table 42. Sub-oscillation Stabilization Time

Oscillator	Conditions	Min	Typ.	Max	Units
Crystal	–	–	–	10	sec
	VDD=3V, T _A =25 °C	–	0.7	1.5	
External clock	SXIN input high and low width (t _{XL} , t _{XH})	5	–	15	μs

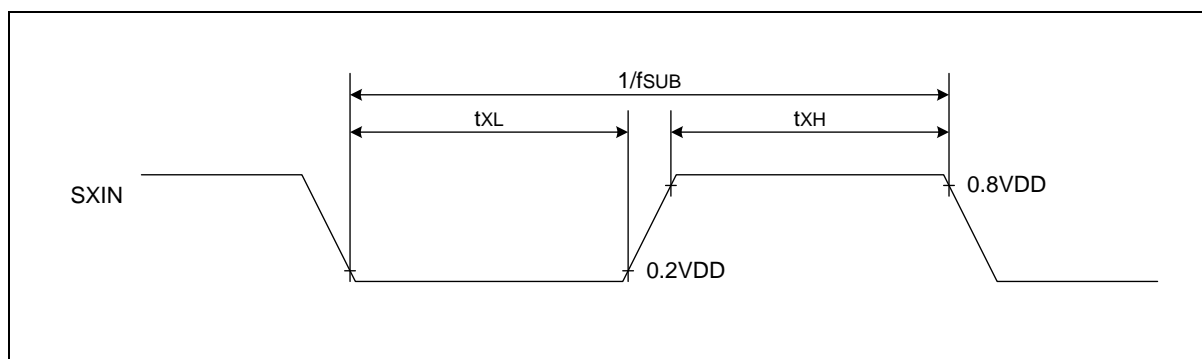

Figure 46. Clock Timing Measurement at SXIN

14.23 Operating voltage range

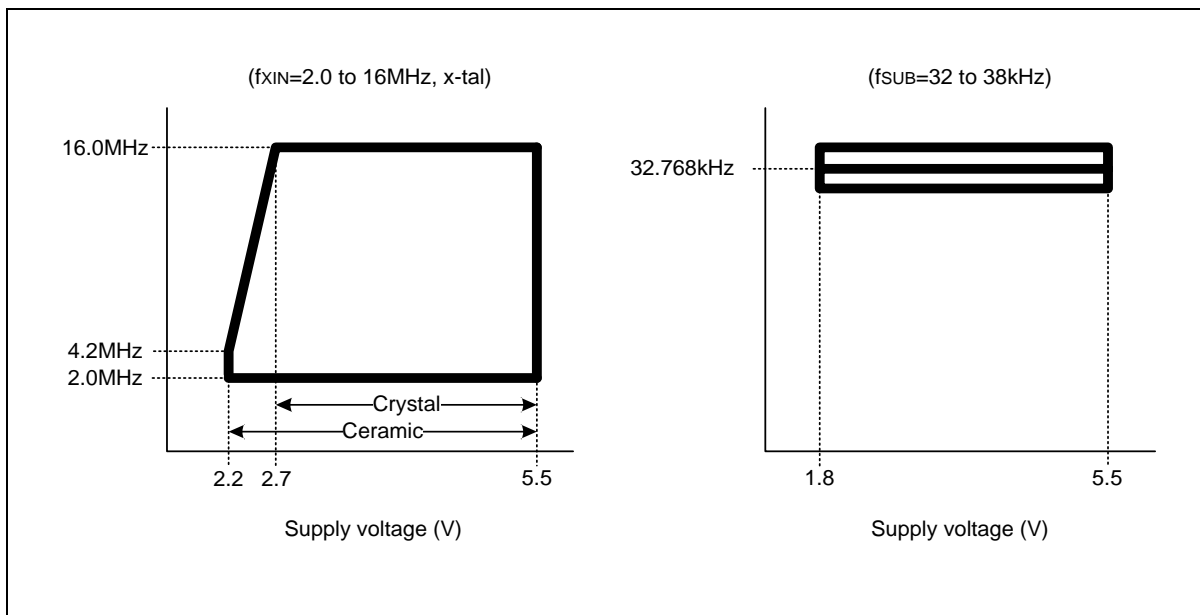

Figure 47. Operating Voltage Range

14.24 Recommended circuit and layout

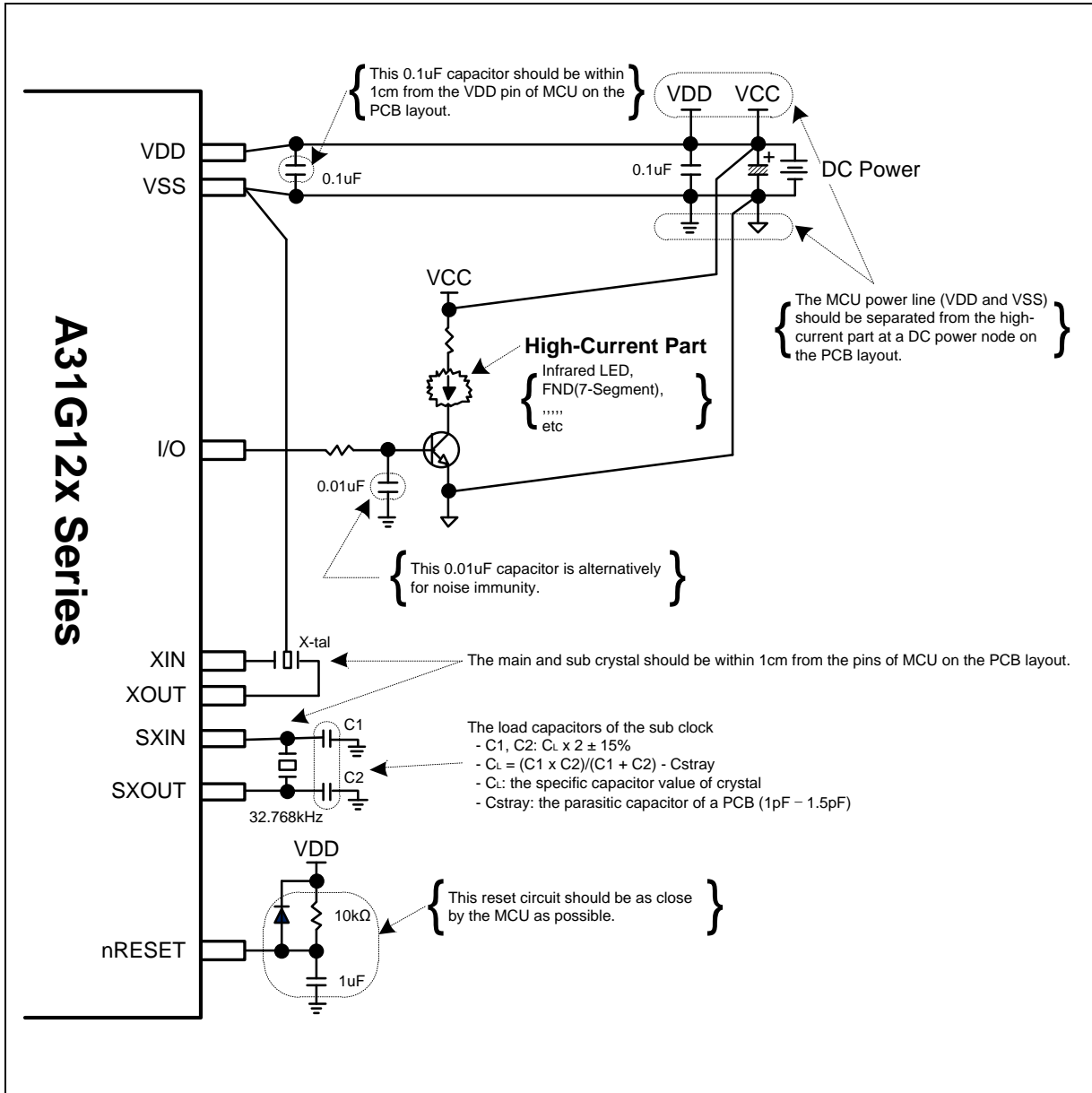

Figure 48. Recommended Circuit and Layout

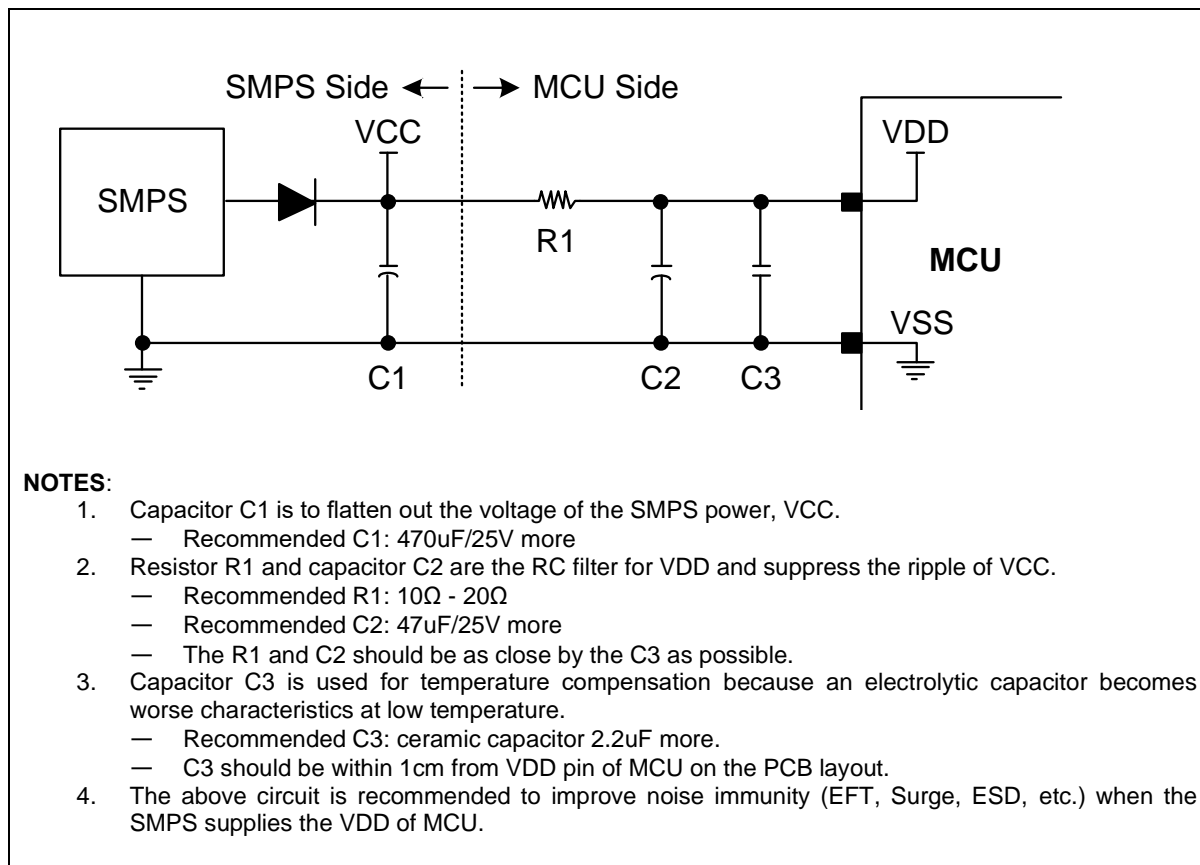

Figure 49. Recommended Circuit and Layout with SMPS Power

15 Package information

15.1 80 LQFP 12x12 package information

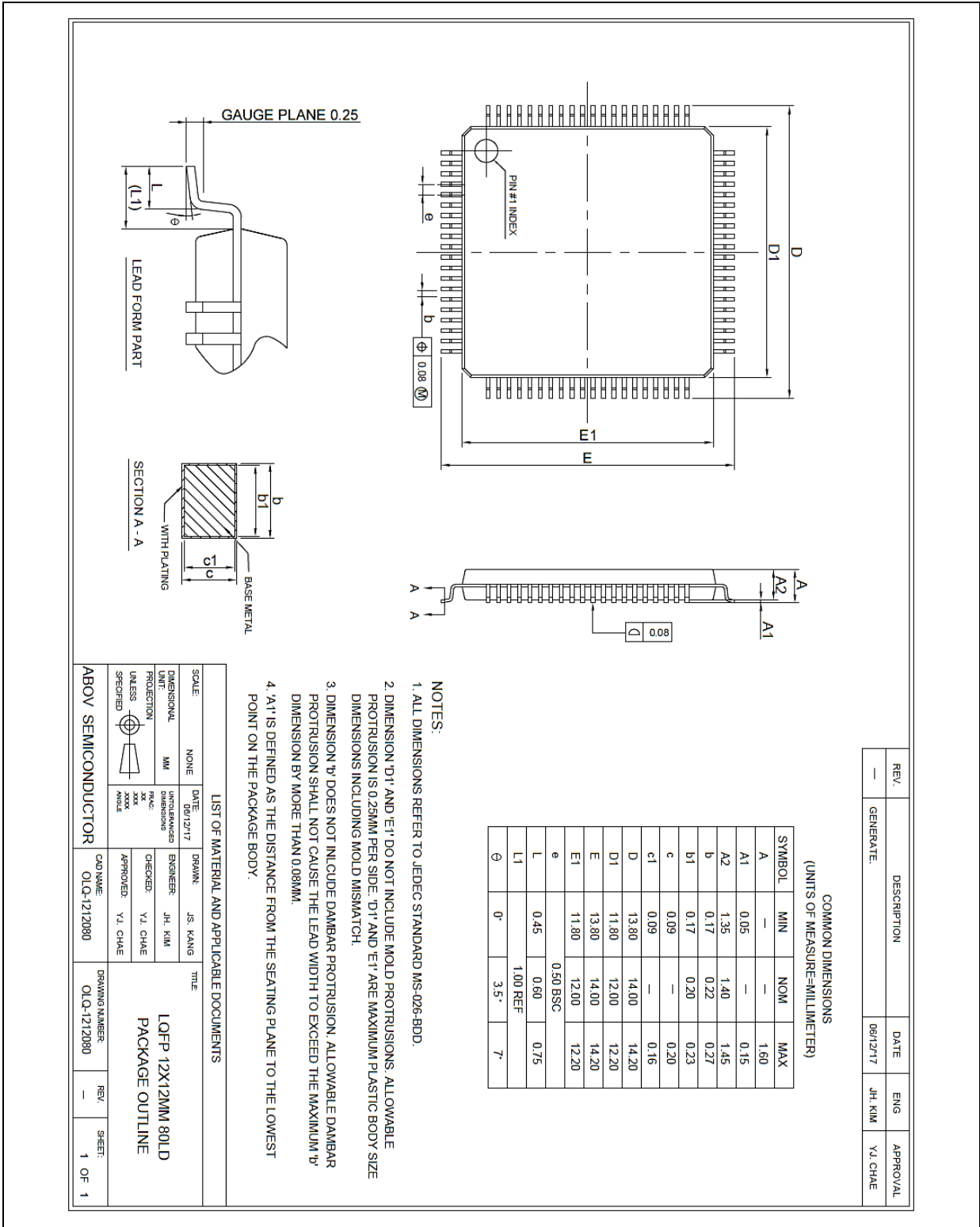

Figure 50. 80 LQFP 12 x 12 Package Outline

15.2 80 LQFP 14x14 package information

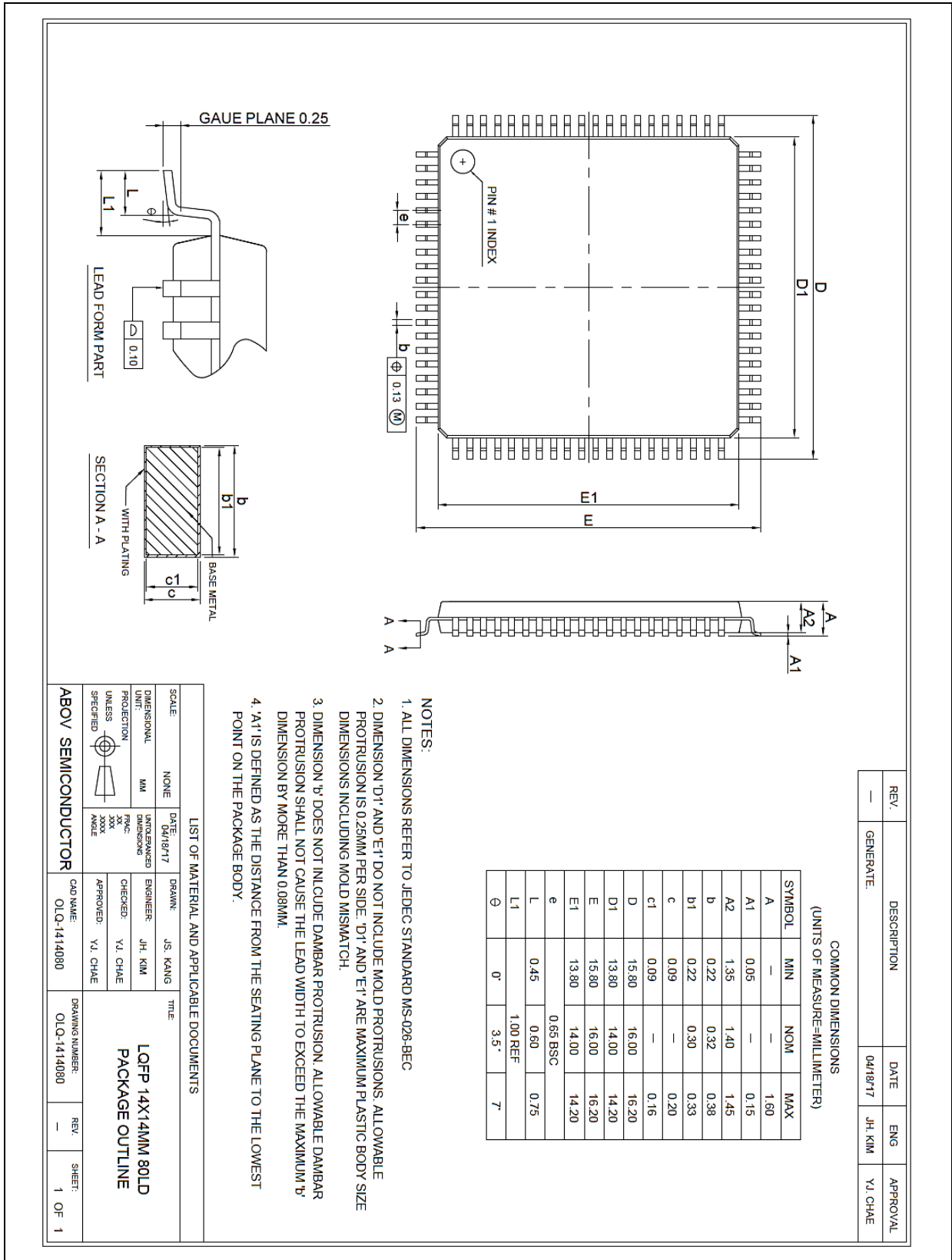

Figure 51. 80 LQFP 14 x 14 Package Outline

15.3 64 LQFP 10x10 package information

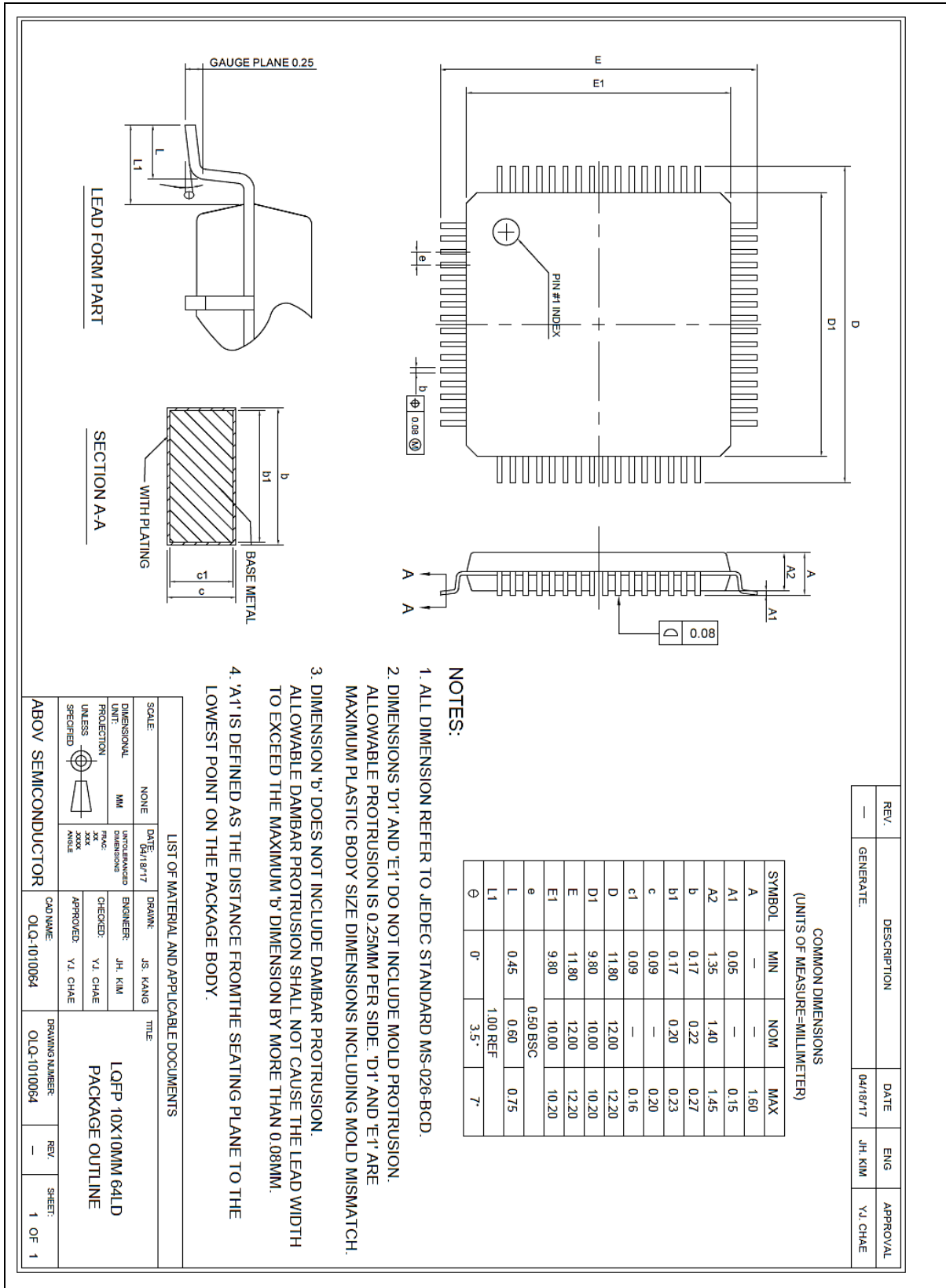

Figure 52. 64 LQFP 10 x 10 Package Outline

15.5 64 LQFP 14x14 package information

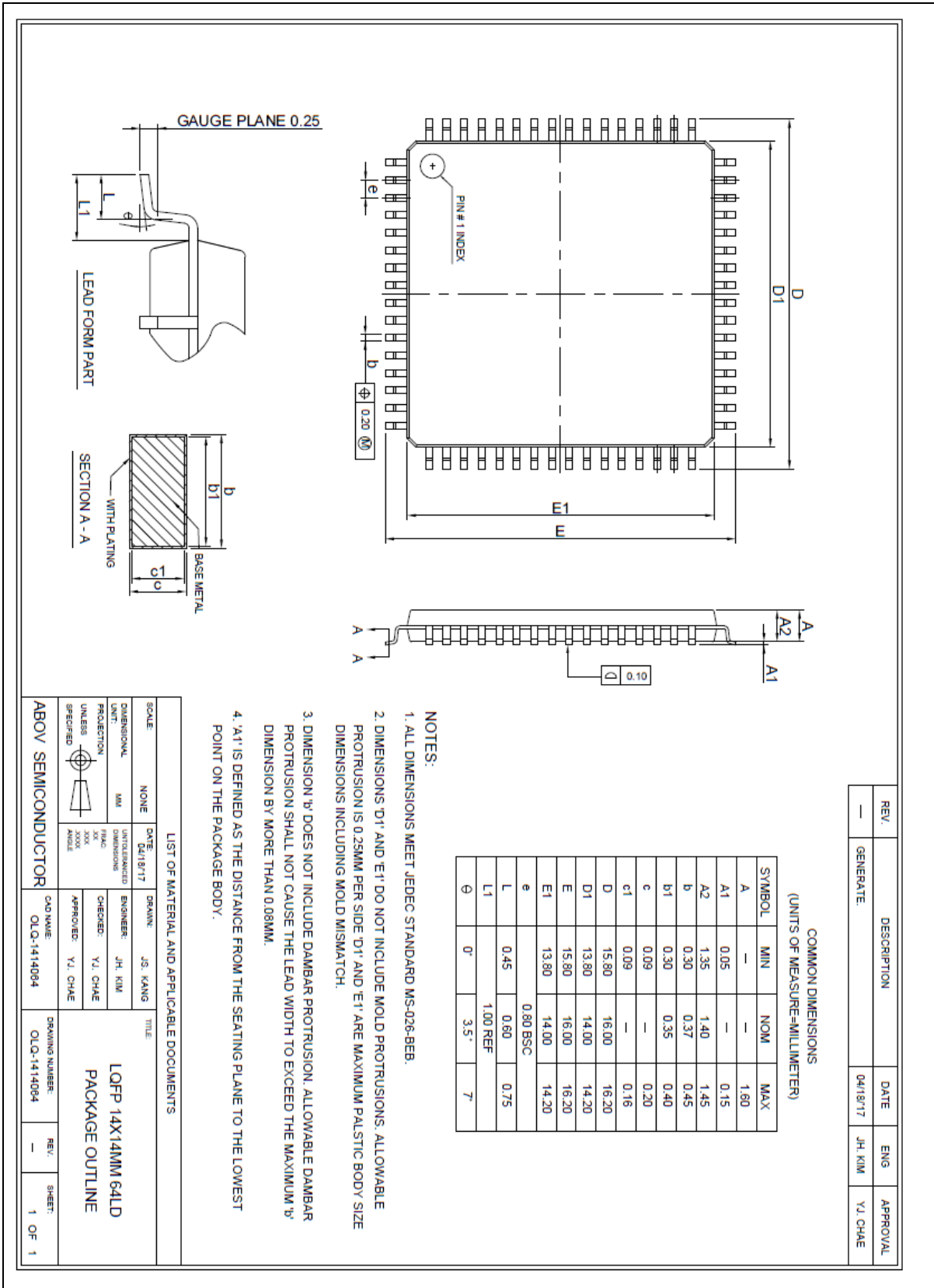

Figure 54. 64 LQFP 14 x 14 Package Outline

15.6 48 LQFP package information

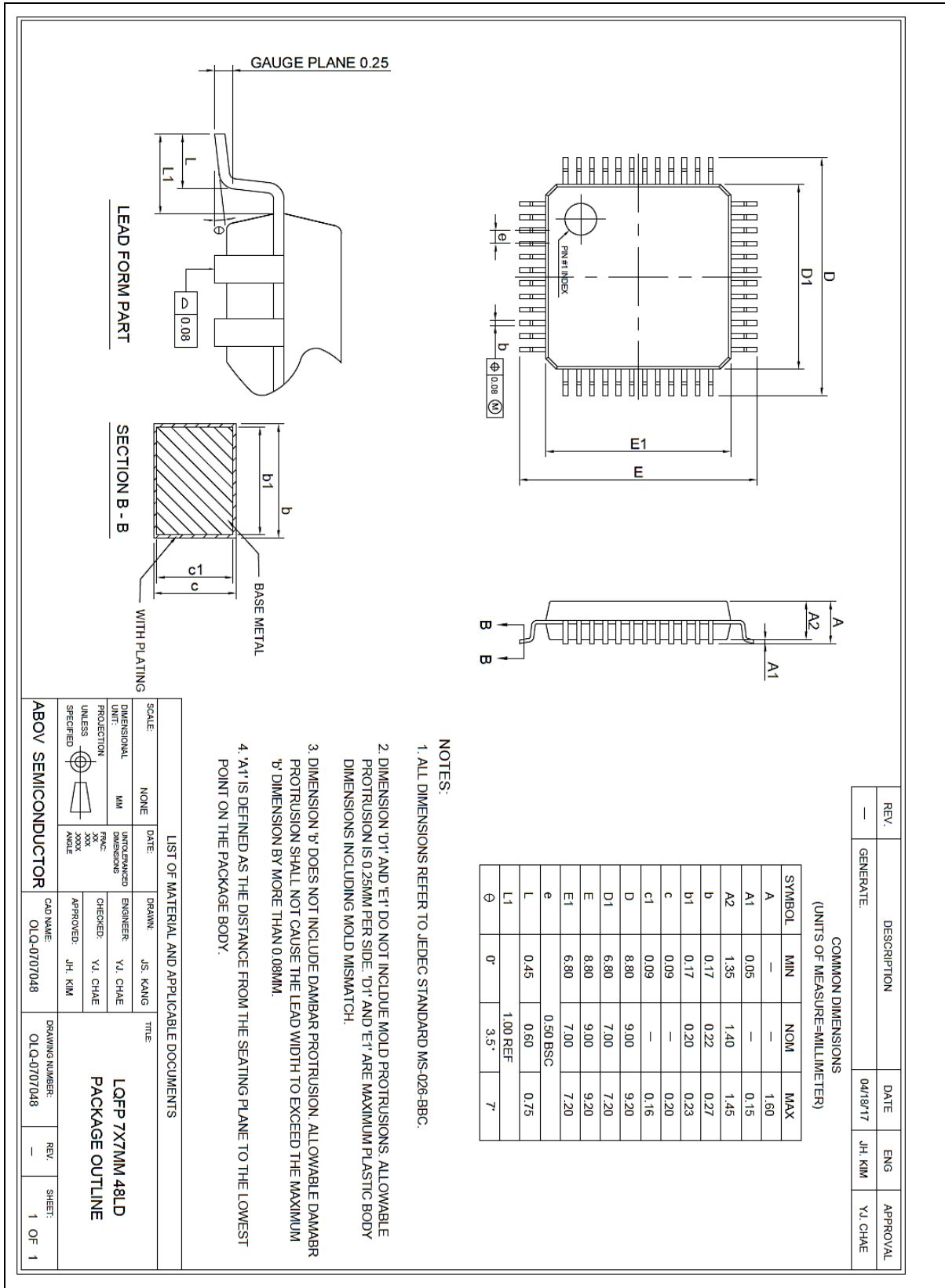

Figure 55. 48 LQFP 07 x 07 Package Outline

15.7 44 MQFP package information

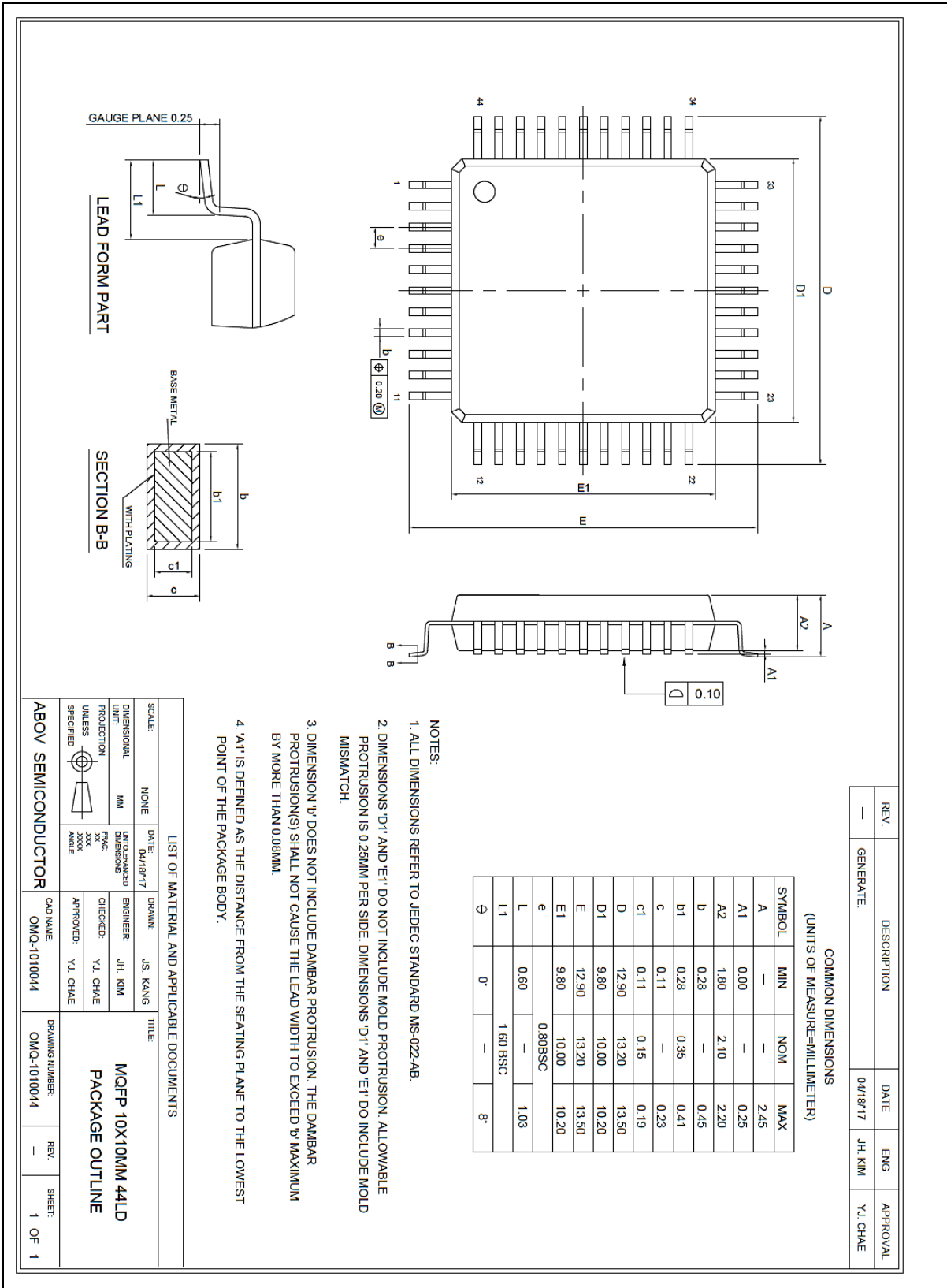

Figure 56. 44 MQFP 10 x 10 Package Outline

16 Ordering information

Table 43. A31G12x series Ordering Information

Part Number	Flash	SRAM	USART	UART	I2C	TIMER	ADC	I/O	Package
A31G123ML	64KB	6KB	4	2	3	10	14 ch	77	80LQFP-1212
A31G123MM*	64KB	6KB	4	2	3	10	14 ch	77	80LQFP-1414
A31G123RL*	64KB	6KB	3	2	3	10	14 ch	61	64LQFP-1010
A31G123RM*	64KB	6KB	3	2	3	10	14 ch	61	64LQFP-1212
A31G123RN*	64KB	6KB	3	2	3	10	14 ch	61	64LQFP-1414
A31G123CL*	64KB	6KB	2	2	2	10	11 ch	45	48LQFP-0707
A31G123SQ*	64KB	6KB	2	2	2	10	9 ch	41	44MQFP-1010
A31G122ML*	32KB	6KB	4	2	3	10	14 ch	77	80LQFP-1212
A31G122MM*	32KB	6KB	4	2	3	10	14 ch	77	80LQFP-1414
A31G122RL*	32KB	6KB	3	2	3	10	14 ch	61	64LQFP-1010
A31G122RM*	32KB	6KB	3	2	3	10	14 ch	61	64LQFP-1212

* For available options or further information on the devices with "*" marks, please contact [the ABOV sales office](#).

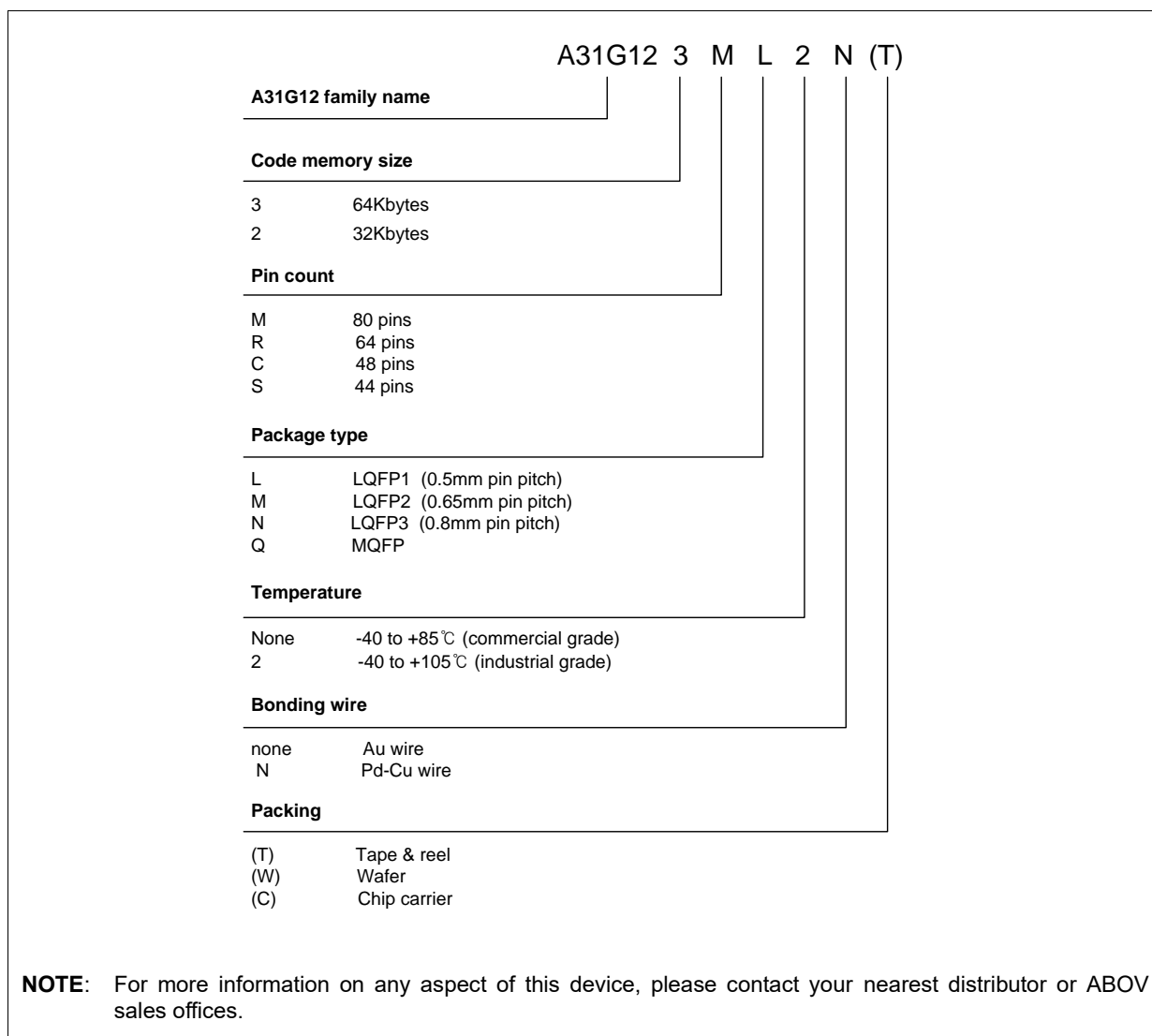

Figure 57. A31G12x series Numbering Nomenclature

17 Development tools

This chapter introduces wide range of development tools for A31G12x series. ABOV offers software tools, debuggers, and programmers to help a user in generating right results to match target applications. ABOV supports entire development ecosystem of the customers.

17.1 Compiler

ABOV semiconductor does not provide any compiler for A31G12x series. However, since A31G12x series have ARM's high-speed 32-bit Cortex-M0+ Cores for their CPU, you can use all kinds of third party's standard compiler such as Keil C Compiler. These compilers' output debug information can be integrated with our A-Link and A-Link Pro. Please visit our website www.abovsemi.com for more information regarding the A-Link and A-Link Pro.

17.2 Debugger

The A-Link and A-Link Pro support ABOV Semiconductor's A31G12x series MCU emulation in SWD Interface. The A-Link and A-Link Pro use two wires interfacing between PC and MCU, which is attached to user's system. The A-Link and A-Link Pro can read or change the value of MCU's internal memory and I/O peripherals. In addition, the A-Link and A-Link Pro control MCU's internal debugging logic. This means A-Link and A-Link Pro control emulation, step run, monitoring and many more functions regarding debugging.

The A-Link and A-Link Pro run underneath MS operating system such as MS-Windows NT/ 2000/ XP/ Vista/ 7/ 8/ 8.1/ 10 (32-bit, 64-bit).

Programming information using the A-Link and A-Link Pro are provided in Figure 58. More detailed information about the A-Link and A-Link Pro, please visit our website www.abovsemi.com and download the debugger S/W and documents.

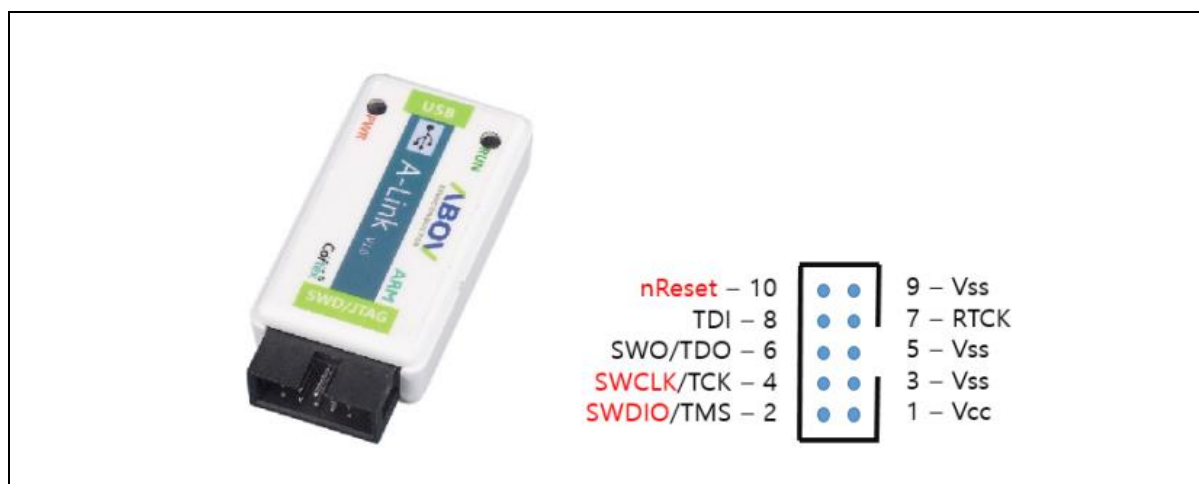

Figure 58. A-Link and Pin Descriptions

17.3 Programmer

E-PGM+

E-PGM+ is a single programmer, and allows a user to program on the device directly.

- Support ABOV devices
- 2~5 times faster than S-PGM+
- Main controller: 32-bit MCU @ 72MHz
- Buffer memory: 1MB

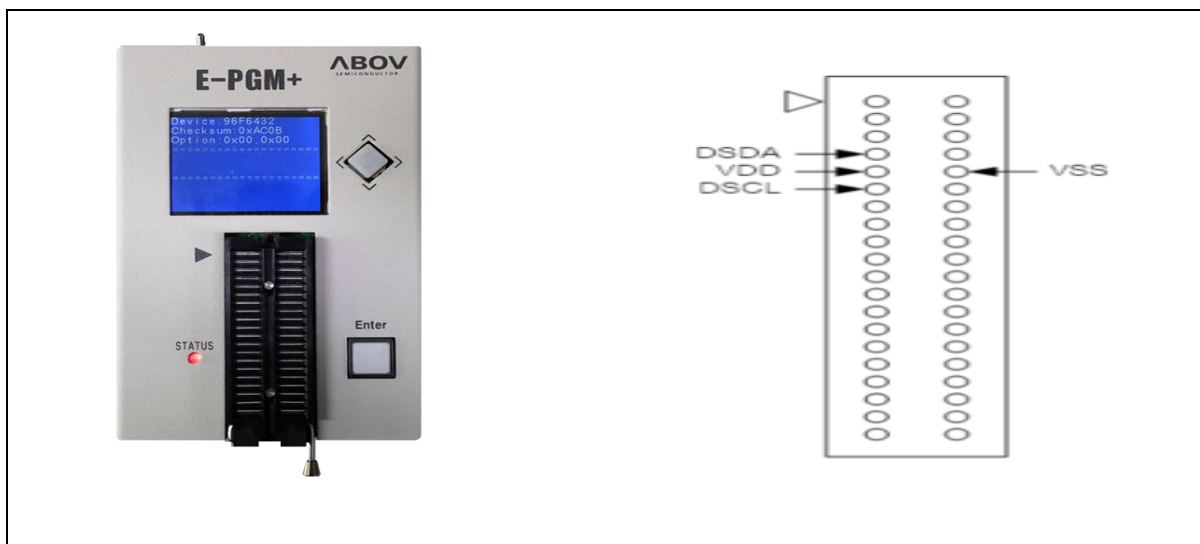

Figure 59. E-PGM+ (Single Writer) and Pin Descriptions

Gang programmer

E-Gang4 and E-Gang6 allows a user to program on multiple devices at a time. They run not only in PC controlled mode but also in standalone mode without PC control. USB interface is available and it is easy to connect to the handler.



Figure 60. E-Gang4 and E-Gang6 (for Mass Production)

17.4 SWD debug mode and E-PGM+ connection

Connections for SWD debugger interface or E-PGM+ is described in figure 61.

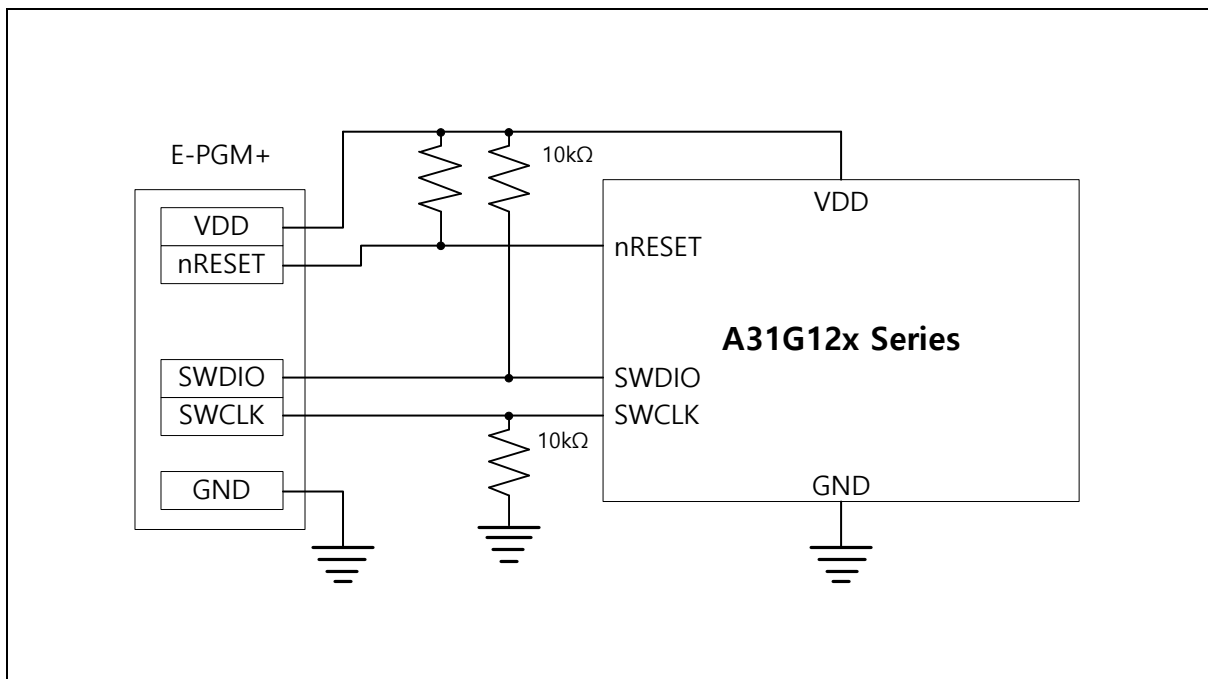

Figure 61. Connection between A31G12x series and E-PGM+ using SWD Debugger Interface

Revision history

Date	Version	Description
Sep.4, 2017	1.0.0	1 st creation
Jan.18, 2018	1.0.1	Add Package Naming Rule
Aug.30, 2018	1.2.0	Change Flash Endurance Times Remove LVR 1.68V/1.77V/1.88V, LVI 1.88V Modify Notes of Clock Monitoring Circuit Diagram in SYSTEM CONTROL UNIT. Modify Notes of Figure 10.1 Block diagram in TIMER COUNTER 30. Update All Package Dimension Remove Special Test in Device Nomenclature Update Operating Temperature Typos modify
Dec.16, 2019	1.2.1	Add a package type, "A31G123RN (64LQFP-1414)". Add notes, "Section 1, Chapter 1. OVERVIEW, Figure 1.3 ~ Figure 1.5." Add a table, "Section 2, Table 1.2 Functional table on current mode". Add notes, "Section 2, Chapter 12. USART 10/11/12/13, Figure 12.2 SPIn Block diagram". Change value, "Section 3, Chapter 2.1.4 Power-On Reset Characteristics". Add a item, "Section 3, Chapter 2.1.17 Internal Flash ROM Characteristics". Modify note, "Section 2, Chapter 16.2.1 CRC Control Register". Typos modify.
Jan.16, 2020	1.2.2	Modify a figure, "Section 1, Chapter 3. BOOT MODE, Figure 3.3". Typos modify
Apr.9, 2020	1.30	Applied a new format to this document.
Nov.30, 2020	1.31	Add a note about disabling "clock monitoring function", "Chapter 5.6.19 SCU_CMONCR", clock monitoring control register. Add notes about TXEn bit and RXEn bit, "Chapter 14.3.1 USARTn_CR1" USARTn control register 1.
Oct.27, 2022	1.40	Change the document format.

Korea

Regional Office, Seoul
R&D, Marketing & Sales
8th Fl., 330, Yeongdong-daero,
Gangnam-gu, Seoul,
06177, Korea

Tel: +82-2-2193-2200

Fax: +82-2-508-6903

www.abovsemi.com**Domestic Sales Manager**

Tel: +82-2-2193-2206

Fax: +82-2-508-6903

Email: sales_kr@abov.co.kr

HQ, Ochang
R&D, QA, and Test Center
93, Gangni 1-gil, Ochang-eup,
Cheongwon-gun,
Chungcheongbuk-do,
28126, Korea

Tel: +82-43-219-5200

Fax: +82-43-217-3534

www.abovsemi.com**Global Sales Manager**

Tel: +82-2-2193-2281

Fax: +82-2-508-6903

Email: sales_gl@abov.co.kr**China Sales Manager**

Tel: +86-755-8287-2205

Fax: +86-755-8287-2204

Email: sales_cn@abov.co.kr**ABOV Disclaimer****IMPORTANT NOTICE – PLEASE READ CAREFULLY**

ABOV Semiconductor ("ABOV") reserves the right to make changes, corrections, enhancements, modifications, and improvements to ABOV products and/or to this document at any time without notice. ABOV does not give warranties as to the accuracy or completeness of the information included herein. Purchasers should obtain the latest relevant information of ABOV products before placing orders. Purchasers are entirely responsible for the choice, selection, and use of ABOV products and ABOV assumes no liability for application assistance or the design of purchasers' products. No license, express or implied, to any intellectual property rights is granted by ABOV herein. ABOV disclaims all express and implied warranties and shall not be responsible or liable for any injuries or damages related to use of ABOV products in such unauthorized applications. ABOV and the ABOV logo are trademarks of ABOV. All other product or service names are the property of their respective owners. Information in this document supersedes and replaces the information previously supplied in any former versions of this document.

© 2020 ABOV Semiconductor – All rights reserved.